



Transit Development Design Guidelines

Providing for the effective, efficient, and
safe integration of transit service into
the built environment



Volusia County MPO



**Transportation
Planning**



Approved by the Volusia County MPO – February 26, 2008

TABLE OF CONTENTS

	Page
INTRODUCTION AND PURPOSE.....	1
BACKGROUND.....	1
The Relationship of Transit-Oriented Design to the “Smart Growth” and “Livable Communities” Movements.....	1
Benefits of Improved Transit Mobility.....	2
HOW TO USE THESE GUIDELINES.....	3
For Developers, Project Planners, Engineers, and Architects.....	4
For Local Government Planners, Engineers, Planning Boards and Elected Officials.....	4
Incorporate the Principles into Plans and Regulations.....	4
DEVELOPMENT REVIEW CHECKLIST.....	9
LAND USE CONSIDERATIONS.....	12
1. Provide appropriate community densities.....	12
2. Promote mixed land uses.....	12
3. Organize density, land use and buildings to benefit from transit service.....	13
4. Minimize walking distance.....	18
5. Create a pedestrian friendly environment.....	19
6. Route into the community.....	19
7. Reduce transit travel time.....	20
8. Build quality, user friendly transit facilities.....	21
RESIDENTIAL LAND USE PRINCIPLES.....	21
1. Density.....	21
2. Network Connectivity.....	21
3. Transit facilities.....	22
RETAIL SHOPPING CENTER LAND USE PRINCIPLES.....	22
1. Mix of Uses.....	22
2. Building Design and Orientation.....	22
3. Network Continuity.....	22
4. Parking.....	22
OFFICE LAND USE PRINCIPLES.....	22
1. Building Design and Orientation.....	22
2. Network Continuity.....	23
3. Parking.....	23
MIXED USE LAND USE PRINCIPLES.....	23
1. Parking.....	23
VEHICLE CHARACTERISTICS.....	24

ROADWAY DESIGN.....	27
Roadway Characteristics.....	27
Lane Width	27
Roadway Grade.....	27
Curb Height	27
Intersection Radii.....	27
Vertical Clearance	28
CLASSIFICATION OF TRANSIT STOPS.....	29
Local Bus Stop	29
Secondary Bus Stop.....	29
Primary Stop.....	29
Park-and-Ride	29
Inter-Modal Transportation Center	29
BUS STOP SITING AND DESIGN	30
Bus Stop Spacing.....	30
Placement (Relationship to Land Use/Development).....	31
Far-Side Stops.....	32
Near-Side Stops	32
Mid-Block Stops.....	33
Curb-Side Bus Stops.....	35
Bus Bays (Pullout or Turnout Bays)	36
Bus Bulbs	36
Infrastructure	37
Bike Racks at Bus Shelters.....	38
Bus Stop Signs.....	39
Bus Benches	39
Bus Stop Leaning Rails	40
Bus Stop Trash Receptacles.....	41
Bus Stop Pads.....	41
Bus Stop Shelters.....	41
Bus Stop Information and Way-Finding Devices.....	46
Bus Stop Shelter Hurricane Wind Loads.....	47
Landscaping	47
Bus Stop Shelter Lighting.....	47
ADA Accessibility.....	48
Appendix A - ADA Accessibility Guidelines for Buildings and Facilities	54

[An excerpt from Appendix A to Part 1191 - Americans with Disabilities Act (ADA) Accessibility Guidelines for Buildings and Facilities] 54

 Accessibility Checklist59

Appendix B - SUGGESTIONS FOR FURTHER CONSIDERATION 61

Appendix C - VOTRAN'S JOINT DEVELOPMENT POLICY 65

Appendix D - RELATED STATUTES AND RULES 67

Appendix E - CRIME PREVENTION THROUGH ENVIRONMENTAL DESIGN (CPTED) 69

 CPTED DESIGN STRATEGIES.....69

LIST OF TABLES

	Page
Table 1 - Project Thresholds for Votran Review.....	6
Table 2 - Development Review Checklist.....	9
Table 3 - Vehicle Specifications	24
Table 4 - 35-ft. Standard Bus Dimensions.....	25
Table 5 - Lane Width and Curb Radii Specifications.....	28
Table 6 - Optimum Bus Stop Spacing	31
Table 7 - Bus Stop Locations: Advantages and Disadvantages of Location Relative to Street Intersections	34
Table 8 - Bus Stop Location Criteria and System Character.....	51
Table 9 - Bus Stop Improvement Standards	52

LIST OF FIGURES

	Page
Figure 1 - Project Development and Review.....	7
Figure 2 - Mixed-use districts along arterials can be made more accessible to transit by reducing the block size and the need for out of direction travel. Bus stop locations are indicated in red dots in plan	13
Figure 3 - Providing access without coordination and cooperation.....	14
Figure 4 - Deviating the route	15
Figure 5 - Installing a pedestrian promenade through the parking lot.....	16
Figure 6 - Orienting building closer to the street and having parking to the rear and sides of the facility.....	17
Figure 7 - Expanding facility	18
Figure 8a - Preferred; direct pedestrian access to transit	19
Figure 8b - Not acceptable; no pedestrian access to transit	19

Figure 9a - Direct Central Routing (Preferred)20

Figure 9b - Peripheral Routing20

Figure 10 - Alternative Bus Turnarounds.....21

Figure 11 - Street Oriented Buildings23

Figure 12a - 35-ft. Standard Bus (side view)24

Figure 12b - 35-ft. Standard Bus (front & rear views).....25

Figure 13 - Standard Bus Turning Template26

Figure 14 - Lane Width and Curb Radii Specifications.....28

Figure 15 - Population Density by Traffic Analysis Zone, Volusia County 200030

Figure 16 - Far Side Bus Stop32

Figure 17 - Near Side Bus Stop.....33

Figure 18 - Mid Block Bus Stop33

Figure 19 - Dimensions for Various Bus Stop Locations.....36

Figure 20 - Near-Side Bus Bulb.....37

Figure 21 - Mid-Block Bus Bulb37

Figure 22 - Far Side Bus Bulb37

Figure 23a - Alternative configurations of bus stops43

Figure 23b - Alternative configurations of bus stops44

Figure 24 - Typical bus shelter layout and design44

Figure 25 - Typical dimensions of a small bus shelter with a leaning rail but no seating, applicable to stops with limited right of way width45

Figure 26 - Cross section of a small bus shelter with a leaning rail but no seating with typical vertical dimensions.....45

Figure 27 - Cross section of a mid-size shelter with typical vertical dimensions.....46

Figure 28a - Typical Bus Stop Layout with Shelter49

Figure 28b - Typical Bus Stop Layout without Shelter50

Figure 29 - Dimensions of Bus Boarding and Alighting Areas54

Figure 30 - Bus Shelters55

INTRODUCTION AND PURPOSE

This document presents a comprehensive set of development design standards that will provide for the integration of transit service into developing and redeveloping areas. The design standards will be useful as a guide to the public, elected officials, planners, developers, engineers, architects and others involved in the planning, design, review and approval of land development projects.

Although planning and designing transit-oriented development and transit-related improvements may seem simple, it often involves consideration of many factors and conflicting objectives. The needs of all roadway and bus users as well as adjacent property owners must be balanced. Therefore, it is important for all stakeholders to be involved at an early stage of project development. The key to effectively coordinating the land development planning and review process with transit service goals is to notify Votran as soon as a new development review application has been submitted so that Votran can participate in the review process when appropriate. Votran encourages local planning or public works departments to become familiar with this document, and when possible, to appoint a regular 'liaison' or staff contact to be responsible for representing the interests of transit in the development review process.

BACKGROUND

With a shift from urban development toward suburban development following World War II, urban planning in general has focused on the automobile as the primary mode of travel. We can expect the automobile to remain the mode of choice long into the future; but, we must recognize that our continuing efforts to widen existing roads and construct new ones cannot keep pace with projected travel demand. Even if we could increase roadway capacity to fully satisfy this demand, the associated air and noise pollution, energy consumption, urban sprawl and land consumption represent a very high price to pay. One alternative is to shift demand to more efficient travel modes, including public transit.

Continuing to focus on the automobile to the exclusion of other travel modes also raises an issue of social justice. The number of persons who do not have ready access to an automobile continues to increase for several reasons including physical and cognitive disabilities, age (too young or too old to drive) and economic hardship. For many of these transportation disadvantaged persons, public transit provides the only reasonable alternative to the automobile, and the only means to access jobs and life-supporting services.

Public transit has the potential to satisfy much of the projected travel demand as well as the current needs of the transportation disadvantaged. However, we can only develop public transit as an economical and effective service if transit services are well integrated into the urban environment. Adding transit services at the end of the planning process, after the roads and land uses are in place and without consideration of the users' requirements and desires, generally means providing less effective, more costly transit service. Consideration of transit in the development planning process should be as integral as consideration of any other essential utility.

The idea of shaping land use to promote more economical and effective transit service has been widely considered in recent years. Various terms have been used to describe this idea including "transit-friendly design", "transit-oriented design" (TOD), "transit-sensitive design" and "transit-supportive design".

Whatever term is used, all seem to agree that economical and effective transit service is best achieved when the density and intensity of development near existing and planned transit routes is increased (usually mixed residential and commercial development), and when transit stops and pedestrian accessways to the stops are designed and constructed to ensure the safety, comfort and convenience of transit riders.

The Relationship of Transit-Oriented Design to the "Smart Growth" and "Livable Communities" Movements

Two current prevailing urban planning and design movements, "Smart Growth" and "Livable Communities", both aspire to achieve more livable, equitable, environmentally-friendly and sustainable cities. Common to both is the principle that citizens should be able to choose among a variety of viable transportation alternatives including transit, and that compact, mixed-use, pedestrian-friendly development is essential for the success of transit.

In 2003, the Volusia County Council adopted Smart Growth as one of its priorities. In the following months, the Volusia County Association for Responsible Development (VCARD) convened a steering committee comprised of representatives from Volusia's local governments, business entities, environmental groups and the general public to direct a series of meetings to consider the value of implementing Smart Growth principles in Volusia County. Participants at these summits concluded that Smart Growth did warrant further consideration. They recommended that a group be formally appointed to develop specific recommendations for implementing Smart Growth in Volusia County. In response to that recommendation, the Volusia Smart Growth Implementation Committee was formed under the sponsorship of Volusia County, Volusia cities, the Volusia County School Board and private interests.

The Volusia Smart Growth Implementation Committee released its final report in August 2005. Among the Committee's many conclusions is that mass transit has the potential to contribute significantly to the Smart Growth goals of compact development and vibrant, walkable, livable communities, if appropriately integrated with other strategies. On that basis, the Committee recommended that the County and cities should cooperate to implement transit options that support Smart Growth. This cooperation should include the following¹:

- Planning, where appropriate, for areas with sufficient density (approximately 8-16 units per/acre or higher) to support transit options such as light rail;
- Support for commuter rail between all of Volusia County and other counties in the region; and
- Support for the transit goals identified by Volusia jurisdictions through the Volusia MPO.

Benefits of Improved Transit Mobility

Transit service can be more efficient, effective, convenient and safe when land development is designed with transit in mind. For transit users, better service means locating bus stops more conveniently with respect to riders' destinations, providing safer and more comfortable waiting facilities, and routing transit vehicles more directly to reduce travel times. For a developer, good transit service means offering the tenants of his development a more accessible location, broader customer base, an expanded labor market, and an option for mitigating the impacts of the development on the transportation system.

In terms of the final outcome, designing for transit service leads to routes that follow roads designed for large vehicles, and transit stops within the development that are convenient and attractive. In general, designing for transit means that it will fit seamlessly into the development contributing to the efficient and effective operation of the transit system as whole, without compromising the efficiency, effectiveness, aesthetics, or other aspects of the development. With proper design and incentives, transit service can attract a variety of activities and uses (retail, community services, and special events). Acting as a stimulus for business activity, commercial redevelopment and neighborhood renewal, efficient and effective transit service can promote our quality of life.

¹ Although the Volusia Smart Growth Implementation Committee's report did not mention the goals and objectives set out in *Votran's Transit Development Plan Major Update 2007-2016* that support Smart Growth, the County and cities should cooperate to implement these transit initiatives, as well. Key among the objectives are:

- Coordinate with local governments for the construction of accessible sidewalks, bus stops, and other bus stop improvements along existing roadways.
- Continue to coordinate with state and local government and transportation agencies the integration of transit needs/amenities into the land use planning and development process.
- Continue to ensure the coordination of all comprehensive plans and other related planning documents.
- Encourage local government to maintain higher densities near arterial and urban collector public transportation corridors.
- Encourage local government to remove land-use barriers that may restrict the use of public transportation.
- Require developers to include public transportation-compatible designs in their projects (e.g., parking lot requirements, bus shelters, bike facilities, sidewalks, etc.).

A report by Pace, the suburban bus division of the Chicago Area Regional Transportation Authority, cited the following benefits of Transit-Oriented Design:

Municipalities

- Enhanced quality of life and development of a pedestrian oriented environment.
- Decreased automobile trips and traffic congestion, leading to reduced travel times for commuters and improved access for emergency and municipal services.
- Increased appeal of municipalities and their developments to the residential and business communities since access to transit is enhanced, passenger convenience and comfort are improved and needed services and workplaces are more accessible by public transportation.
- Reduced environmental impacts from air pollution, roadway expansions into open space and excessive energy consumption.

Developers

- Increased compatibility between transit service and the development's internal roads, walkways and transit facilities.
- Decreased need for parking facilities which, in turn, decreases the construction and maintenance costs related to parking.
- Increases developable land as parking space needs decrease.
- Increased attractiveness of the site to prospective buyers or tenants because the site is accessible to a broad population.

Businesses

- Increased potential to expand business labor pools to a greater number of locations and to those individuals who do not own private vehicles.
- Enhanced access to customers.
- Increased travel alternatives for employees which can result in a reduced number of on-site vehicles and vehicle congestion.
- Increased access by employees that can improve employee punctuality and attendance.
- Decreased need for parking facilities which, in turn, decreases construction and maintenance costs related to parking.

Transit Users

- Enhanced access to transit by the pedestrian and mobility limited population.
- Improved passenger convenience and comfort.
- Increased accessibility to needed services and work places by public transportation.
- Increased travel alternatives.

HOW TO USE THESE GUIDELINES

These guidelines should be used by private and public sector developers and their project planners, engineers and architects when planning or designing any development or redevelopment project. They should also be used by local government staffers as they review private sector project proposals for approval and when they plan and design public sector improvements (e.g., roads, government offices, libraries, schools, parks and recreation facilities and other community facilities).

It is generally appropriate to apply these principles related to transit vehicle circulation and transit accessibility; and it is particularly important to do so when transit service is available or is expected to be available. Votran should be contacted if there is any doubt about the current or future availability of transit

service to the project. Votran would like to review the project proposal if it is known that transit service is currently available or will be available in the future and the project exceeds the threshold shown in Table 1 on page 6.

For Developers, Project Planners, Engineers, and Architects

One of the earliest considerations, even before preparing a conceptual design, should be whether the proposed development is located within an existing or future transit service area. Votran can be contacted to determine what transit service options may be available at the project site. If transit service is available at the site, or will be available in the foreseeable future, the fundamental elements of the development including type of use, density or intensity, and form can usually be tailored to better support transit service and to reap greater benefits from the availability of transit service.

Votran will not normally review a development proposal or plan; however, if the proposed development is deemed to be “significant” with respect to its impact on transit service, then the developer is encouraged to involve Votran in the review process at a very early stage. (See Table 1 on page 6.)

Votran encourages developers to consider these guidelines carefully, and to incorporate the transit design features into every project that will be served by transit. Even projects that will not be served by transit in the foreseeable future should incorporate the design features that are not specific to transit for the contributions those features will make toward a more “livable community”.

Developers may perform their own project evaluations by completing the “Development Review Checklist” on page 9.

For Local Government Planners, Engineers, Planning Boards and Elected Officials

The needs of transit service providers and users, pedestrians and bicyclists should be routinely considered in the review of every development proposal just as automobile access and parking, landscaping, and utilities are now considered.

If a development is proposed in an area where transit service exists or is anticipated, it should be designed to integrate and support it, not just accommodate it. For that, it is necessary for transit-friendly design principles to be reflected in the basic elements of a development. It can not be achieved by adding “window dressings”.

Local government planners, engineers, planning board members and governing board members should be well acquainted with the principles of transit-friendly design described in this document so that they will better recognize at an early stage whether a development proposal does appropriately integrate and support transit service. It is best to raise transit service considerations at the conceptual plan review stage or earlier, before a developer has expended time and money on design and engineering.

The Development Review Checklist on page 9 can be used as an aid for plan review to ensure that all principles are given due consideration.

Incorporate the Principles into Plans and Regulations

Many local governments in Volusia County have included in their comprehensive plans, goals, objectives and policies which support compact development and multi-modal transportation systems. However, successful implementation will require a degree of integration between land use and transportation planning that may not be evident in those plans. Local governments should review their plans to see if they can be amended to promote closer integration. Of course, coordination with Votran will be important to ensure that transit service can be provided to support anticipated development.

Local governments are encouraged to review their land development codes to incorporate transit-supportive design principles as appropriate. Some principles can be adequately addressed by inclusion of specific language, while others may require much broader consideration of the codes and how seemingly unrelated provisions can impact transit service and accessibility to transit. By incorporating these guidelines into land

development codes, consideration of transit will be “institutionalized” and developers will be better informed of the local government’s expectations.

If the local government with responsibility to approve a development proposal has staff with training in the transit service field, the review can be done in-house. Otherwise, the Votran staff or MPO staff (or both) can assist with the review.

Table 1 - Project Thresholds for Votran Review

PROJECT TYPE	THRESHOLD
COMMERCIAL/INDUSTRIAL	
Retail store/Shopping Center (big box store, mall, shopping plaza, major grocery store)	25,000 sq. ft. of floor area or 10 acres;
Office or industrial building	200 employees
RESIDENTIAL/MIXED USE	
Multi-family residential development	500 dwelling units
Residential/non-residential mixed use	100 acres
Senior/Low-Income, Affordable (Assisted Living Facilities, Nursing Homes, Manufactured Housing, Adult Communities)	All
MEDICAL	
Hospital, clinic, or other medical or social services provider	All
Medical Office/Complex	5,000 sq. ft.
Urgent Care Facility	All
Medical Laboratory/Testing Center	5,000 sq. ft.
Dialysis Center	All
RECREATIONAL	
Sports Complex (Speedway, dog track, YMCA, etc.)	1,000 person occupancy
Entertainment Facility (multiplex theaters, entertainment complexes, etc.)	All
Parks	10 acres
Major Area Attractions (historic sites, nature activities, etc.)	All
PUBLIC SECTOR/GOVERNMENT	
Government Offices	All
Social Service Agencies (VA, DCF, Social Security, Workforce Development, etc.)	All
Libraries	All
Community Centers	All
EDUCATION FACILITIES	
Public or private school	Public schools, private schools and colleges with at least 500 students
ROAD CONSTRUCTION	
Arterial or Collector Road Construction/Reconstruction	New roadway, re-alignment or extension of an existing roadway, or reconstruction of an existing roadway (adding lanes, reconfiguring lanes, reconfiguring curblines, adding, removing or reconfiguring sidewalks)
OTHER	
Developments of Regional Impact (DRIs)	All

Figure 1 - Project Development and Review

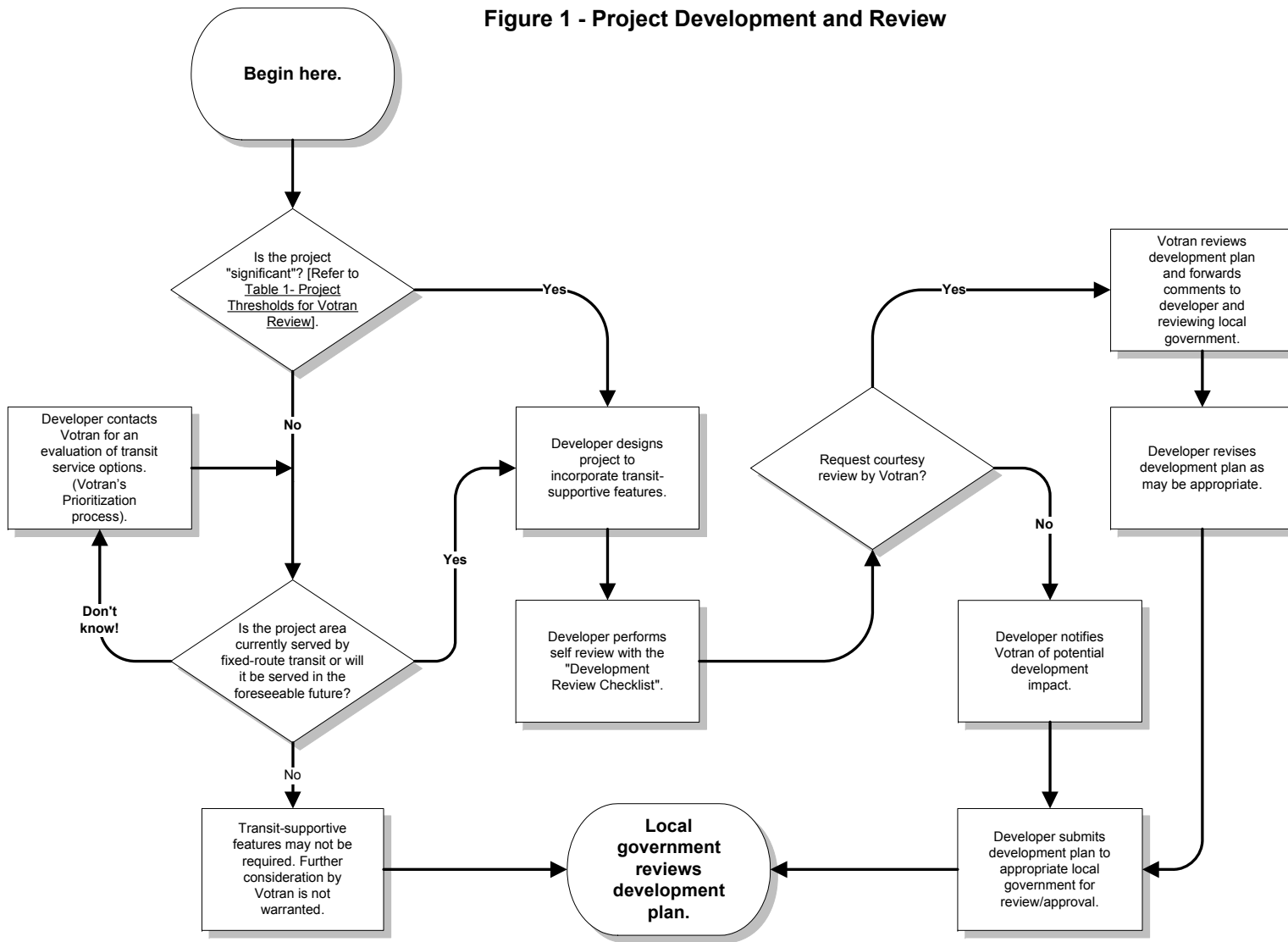

[This page is intentionally blank.]

DEVELOPMENT REVIEW CHECKLIST

The Development Review Checklist should be used to evaluate how well a proposed development will accommodate transit vehicle circulation and provide for accessibility to transit services. Development plans can be evaluated by answering the questions on the checklist. These questions are designed to receive a "Yes" response if the development will accommodate transit vehicles and provide satisfactory access to public transit. If a "Yes" response is not received, the reviewer should refer to the appropriate report section for design suggestions. If further assistance is required, Votran will review development plans and provide transit-related design suggestions and technical assistance.

Table 2 - Development Review Checklist

<input checked="" type="checkbox"/> Yes	<input checked="" type="checkbox"/> No		Subdivisions	Multi-Family Developments	Retail Commercial and Office Developments	Industrial Developments	Hospitals, Clinics, Educational Facilities and Other Institutions	Mixed Use Developments	Road Construction and Reconstruction
Pedestrian Circulation									
		Is the development designed to provide for safe and convenient pedestrian circulation?	■	■	■	■	■	■	■
		Have sidewalks been provided on both sides of every street?	■	■	■	■	■	■	■
		Have safe street crossings been provided at intersections?	■	■	○	■	○	■	■
		Are walkways, curbs, bus stops, building entrances, parking areas and transit facilities designed in compliance with ADA requirements?	■	■	■	■	■	■	■
		Have short, direct pedestrian linkages been provided between key points in and around the proposed development including existing and potential transit stops?	■	■	■	■	■	■	■
		Have direct pedestrian linkages been provided to adjacent land uses?	■	■	■	■	■	■	■
		Have all unnecessary barriers to pedestrian circulation (e.g., perimeter walls, drainage ditches, and landscaped berms) been eliminated?	■	■	■	■	■	■	■
		Is lighting adequate for pedestrian safety and security?	■	■	■	■	■	■	■
Bicycle Circulation									
		Is the development designed to provide for safe and convenient bicycle circulation?	■	■	■	■	■	■	■
		Is the bicycle circulation system designed in accordance with applicable standards?	■	■	■	■	■	■	■
		Have short, direct linkages been provided for bicyclists between key points in and around the proposed development including existing and potential transit stops?	■	■	■	■	■	■	■
		Have secure bicycle parking facilities been provided in "high use" areas?	○	■	■	■	■	■	○

Yes	No		Subdivisions	Multi-Family Developments	Retail Commercial and Office Developments	Industrial Developments	Hospitals, Clinics, Educational Facilities and Other Institutions	Mixed Use Developments	Road Construction and Reconstruction
<input checked="" type="checkbox"/>	<input checked="" type="checkbox"/>	Vehicular Circulation							
		Does the proposed development provide for a well-connected street network including connections for vehicle travel to neighboring developments (existing or future) on all sides?	<input type="checkbox"/>	<input type="checkbox"/>	<input type="checkbox"/>	<input type="checkbox"/>	<input type="checkbox"/>	<input type="checkbox"/>	<input type="checkbox"/>
		Are the streets designed for safe and efficient use by all users?	<input type="checkbox"/>	<input type="checkbox"/>	<input type="checkbox"/>	<input type="checkbox"/>	<input type="checkbox"/>	<input type="checkbox"/>	<input type="checkbox"/>
		Transit Circulation							
		Has Votran been contacted to determine if transit service currently exists or will be provided to the proposed development? (See page 4 to determine when Votran should be contacted to determine what transit service provisions may be provided.)	<input type="checkbox"/>	<input type="checkbox"/>	<input type="checkbox"/>	<input type="checkbox"/>	<input type="checkbox"/>	<input type="checkbox"/>	<input type="checkbox"/>
		Are large-scale developments designed to allow for direct routing of transit vehicles through the center of the development? (Note that direct routing through a development will be considered only if Votran deems it to be appropriate.)	<input type="checkbox"/>	<input type="checkbox"/>	<input type="checkbox"/>	<input type="checkbox"/>	<input type="checkbox"/>	<input type="checkbox"/>	<input type="checkbox"/>
		For all intersections and driveways that will accommodate transit vehicles, are corner radii designed for a 50-ft. outside and 30-ft. inside turning radius?	<input type="checkbox"/>	<input type="checkbox"/>	<input type="checkbox"/>	<input type="checkbox"/>	<input type="checkbox"/>	<input type="checkbox"/>	<input type="checkbox"/>
		For all roadways and driveways that will accommodate transit vehicles, are grades 6% or less?	<input type="checkbox"/>	<input type="checkbox"/>	<input type="checkbox"/>	<input type="checkbox"/>	<input type="checkbox"/>	<input type="checkbox"/>	<input type="checkbox"/>
		For all roadways and driveways that will accommodate transit vehicles, are lane widths at least 12 feet?	<input type="checkbox"/>	<input type="checkbox"/>	<input type="checkbox"/>	<input type="checkbox"/>	<input type="checkbox"/>	<input type="checkbox"/>	<input type="checkbox"/>
		Will roadside improvements and landscaping allow adequate vertical and horizontal clearance for transit vehicles?	<input type="checkbox"/>	<input type="checkbox"/>	<input type="checkbox"/>	<input type="checkbox"/>	<input type="checkbox"/>	<input type="checkbox"/>	<input type="checkbox"/>
		Where development will be phased and transit routes are incomplete in preliminary phases, have interim bus turnaround facilities been provided?	<input type="checkbox"/>	<input type="checkbox"/>	<input type="checkbox"/>	<input type="checkbox"/>	<input type="checkbox"/>	<input type="checkbox"/>	<input type="checkbox"/>
		Are transit stops ADA accessible? Do any obstacles exist (swales, ditches, retaining walls, etc.)?	<input type="checkbox"/>	<input type="checkbox"/>	<input type="checkbox"/>	<input type="checkbox"/>	<input type="checkbox"/>	<input type="checkbox"/>	<input type="checkbox"/>
		Transit Stop and Terminal Design							
		Has Votran been contacted to determine if new transit stops will be needed on or adjacent to the site of the proposed development? (See page 4 to determine when Votran should be contacted to determine what transit service provisions may be provided.)	<input type="checkbox"/>	<input type="checkbox"/>	<input type="checkbox"/>	<input type="checkbox"/>	<input type="checkbox"/>	<input type="checkbox"/>	<input type="checkbox"/>
		If the developer is to provide transit stop improvements, have the location, design and construction specifications been approved by Votran?	<input type="checkbox"/>	<input type="checkbox"/>	<input type="checkbox"/>	<input type="checkbox"/>	<input type="checkbox"/>	<input type="checkbox"/>	<input type="checkbox"/>

Yes <input checked="" type="checkbox"/>	No <input checked="" type="checkbox"/>		Subdivisions	Multi-Family Developments	Retail Commercial and Office Developments	Industrial Developments	Hospitals, Clinics, Educational Facilities and Other Institutions	Mixed Use Developments	Road Construction and Reconstruction
		Is additional right-of-way needed at existing or proposed transit stops to accommodate recommended transit facilities and improvements?	■	■	■	■	■	■	■
		If transit stops are proposed, will they be located where they will not be an intrusion (e.g., adjacent to parks, retention areas or other public areas rather than adjacent to dwellings)?	■	■	⊙	⊙	⊙	■	⊙
		Are transit stops located in reasonable proximity to primary destinations?	■	■	■	■	■	■	■
Building and Parking Location									
		Are buildings located forward on the property to minimize walking distances from sidewalks and transit routes, and to create a safe, convenient, comfortable and visually interesting environment for pedestrians?	⊙	■	■	■	■	■	⊙
		Are parking areas located behind or to the side of the buildings so that pedestrians don't have to walk across them? Or, have short, direct and safe walkways been provided from the sidewalk and transit stops to the buildings' main entrances?	⊙	■	■	■	■	■	⊙
		Are parking lots and building entrances adequately lighted for pedestrian safety and security?	■	■	■	■	■	■	■
Building Design									
		Do office, educational, institutional and industrial developments over 25,000 square feet have lobbies designed with passenger waiting areas proximate to transit stops?	⊙	⊙	■	■	■	■	⊙
		Are retail commercial buildings oriented to the sidewalk and designed to include pedestrian-level display windows and awnings?	⊙	⊙	■	⊙	⊙	■	⊙
		Do overhangs and covered drop-off points have sufficient clearance height for transit vehicles?	⊙	■	■	■	■	■	⊙

Key: ■ = applicable; ⊙ = not applicable

LAND USE CONSIDERATIONS

The low-density, homogeneous land use pattern that characterizes suburban development is often cited as a principal reason for our limited success in providing good transit service. Trips generated by sprawling residential development and extensive strip commercial development are highly diverse. Transit can't operate efficiently under such circumstances. To operate efficiently, transit needs relatively high volumes of trips with concentrated origins and destinations. Such trip patterns are most likely when land uses are mixed and concentrated in corridors.

Higher development density and intensity alone will not ensure an adequate level of support for good transit service. Virtually every trip on transit begins and ends as a pedestrian trip. Pedestrians are discouraged from using transit that is not conveniently and safely accessible. Therefore, community design that provides for direct, secure pedestrian movement between transit stops and nearby points of origin or destination is essential. Good pedestrian accessibility requires a continuous, fine-grained network of sidewalks and safe street crossings. An environment that allows pedestrians to feel comfortable and secure, both physically and psychologically, is also important.

In order to improve the quality of transit service in Volusia County, we must encourage more transit-supportive development. Key concepts that define transit-supportive development are described below.

1. Provide appropriate community densities

The quality (frequency of service), range (service choices) and duration (hours of operation) of transit service that can be provided in an area are directly related to population and employment densities in the service area. Low population and employment densities cannot generate enough transit ridership to justify a desirable transit level of service. "The old rule of thumb is that seven units per acre are required to support basic bus service. For premium bus service, the required residential density rises to 15 units per acre."²

To be cost-effective, transit ridership must reach a sufficient sized pool of potential riders. Development of population or jobs above minimum levels should be encouraged.

Relatively high resident and employment population densities are necessary to provide transit service with short headways.

2. Promote mixed land uses

When land uses are mixed, transit riders are better able to satisfy more than one trip purpose with a single trip, for example, picking up a movie at the video store and a gallon of milk at the convenience store on the way home from work. When the mix of uses brings people to an area for extended periods of the day, the area will usually be safer because there is more community surveillance. Community surveillance is a fundamental principal of Crime Prevention through Environmental Design (CPTED). It holds that people are generally less likely to commit a crime or improper act when there is a witness.

A mixed use pattern that puts residential units above street level commercial uses can contribute to increased residential densities along transit corridors without a corresponding decrease in commercial intensity; and it does so while establishing vertical separation for greater residential privacy and serenity.

Higher density/intensity mixed-use areas should include refuges where a pedestrian can pause to collect himself. These spaces may simply be a recessed building entry with a tree and a bench, or a landscaped buffer between the sidewalk and a parking lot. They should be easily accessible to pedestrians and visible from the sidewalk, and they should be rich with features such as textured pavements, landscaping, fountains or sculptures.

² Pedestrian and Transit-Friendly Design: A Primer for Smart Growth, by Reid Ewing, based on a manual prepared for the Florida Department of Transportation and published by the American Planning Association.

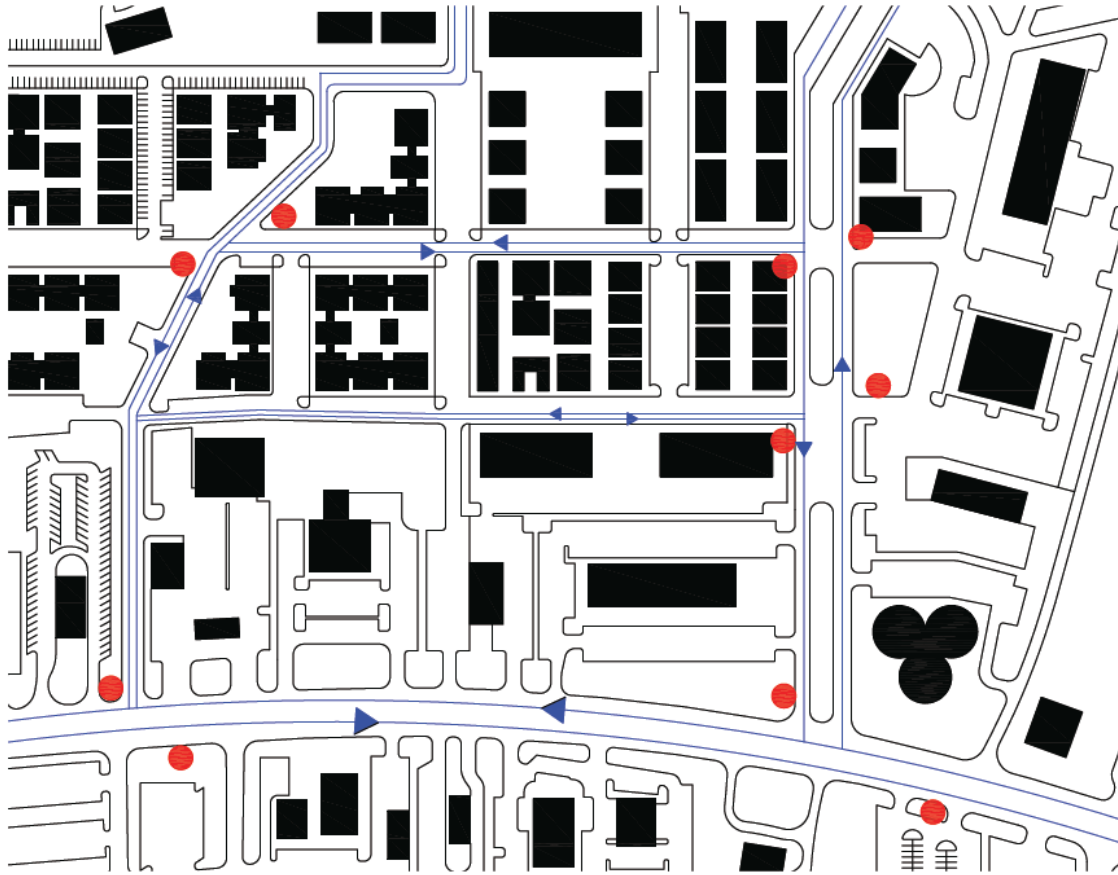

Figure 2 - Mixed-use districts along arterials can be made more accessible to transit by reducing the block size and the need for out of direction travel. Bus stop locations are indicated in red dots in plan.

Source: [Accessing Transit: Design Guidelines for Florida Bus Passenger Facilities](#), Report Prepared for: Florida Department of Transportation, Public Transit Office By: Florida Planning and Development Lab, Department of Urban and Regional Planning, Florida State University, March 2004.

3. Organize density, land use and buildings to benefit from transit service

- Density should be organized to take advantage of transit service.

Higher density and intensity development should be concentrated along transit corridors and within ¼-mile of transit transfer or inter-modal centers. Ideal land uses include multi-family and small-lot single-family residential projects, offices and medium intensity employment centers, institutions, and smaller retail centers. Development requiring large areas of land for parking and other purposes, and characterized by low residential densities or low rates of employment should be discouraged from locating in core transit service areas or within ¼-mile of a transit transfer or inter-modal center. Examples include “big box” retail outlets, automobile, boat and RV sales lots, and builders supply outlets which have floor area ratios of less than 0.25 and 4 or more parking spaces per 1,000 sq. ft. of floor area.

- Buildings should be moved close to streets, intersections and transit stops.

Buildings should be designed and located to provide pedestrians with a safe, convenient, comfortable and visually interesting environment that reduces perceived travel distances and increases the legibility of the pedestrian networks.

Aligning buildings close to the street creates a sense of closure, intimacy and security for pedestrians; lining the street with trees can also help to create a sense of closure. Where buildings are placed close to the street, they should be designed to provide protection from the sun and rain.

Canopies, awnings and arcades are standard fare in urban design manuals. Expansive blank walls and open parking areas, perceived by pedestrians as “dead spaces” and “hostile zones” should be minimized.

In suburban office and industrial parks, clustering buildings at intersections close to the street will make them convenient to transit stops, street crossings and other buildings. Developments or single sites that cluster the buildings close to the street should incorporate a street level design that encourages pedestrian activities.

Pedestrian entrances to buildings should be oriented toward the sidewalks, transit stops and other buildings to minimize walking distances between buildings and transit service.



Figure 3 - Providing access without coordination and cooperation

Source: Volusia County MPO.

Positives:

- Bus remains on a main thoroughfare, minimizing total travel time along the bus route.
- Bus stop is more visible to passing vehicles and helps advertise the availability and location of public transit.

Negatives:

- Patrons must walk through a vast parking lot to reach the facility.
- Potential exists for vehicular and pedestrian conflicts as patrons walk through parking lot.
- Parking lot is uninviting and offers little in the way of environmental comfort.
- Security of patrons may be compromised as they walk through parking lot.



Figure 4 - Deviating the route

Source: Volusia County MPO.

Positives:

- Permits bus route to access land uses more directly.
- Reduces walking time and distance from the land use to the bus stop.
- Improves accessibility for persons with limited mobility.
- Potential for shared use of overhang for bus patrons during inclement weather.
- Reduces the potential for vehicular/pedestrian conflicts in the parking lot.
- Patron security may be enhanced through proximity to land use. Indirect surveillance from the land use may be increased and the number of potential hiding places is removed by placing the stop adjacent to the building.

Negatives:

- Bus/general vehicle conflicts may increase by having the route deviate into the parking areas.
- Route travel time and distance are increased.

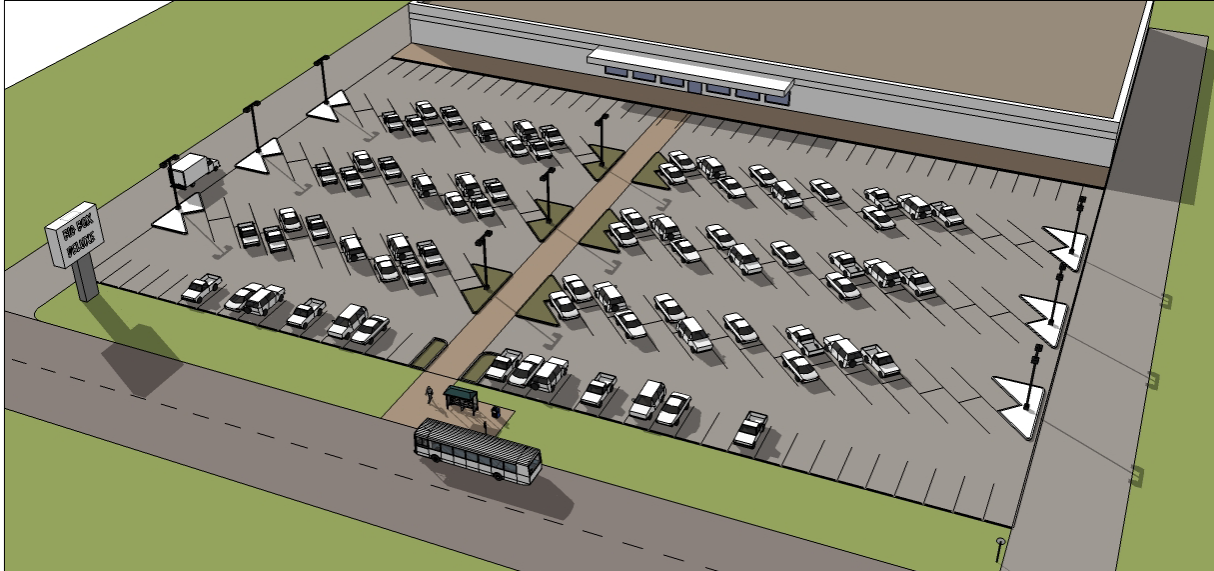

Figure 5 - Installing a pedestrian promenade through the parking lot

Source: Volusia County MPO.

Positives:

- Bus vehicle remains on a main thoroughfare, minimizing trip time and distance.
- Reduces opportunity for pedestrian/vehicular conflicts in parking lot by constructing a well-defined pedestrian corridor.
- Patron comfort is enhanced by providing shade trees along a promenade.
- Security of patrons may be enhanced if the promenade is well-lit.

Negatives:

- Does not reduce walking distance or time between the land use and the bus stop.
- Patron security may still be compromised if the promenade is not well used, well lit, or sight-lines are restricted by vegetation.

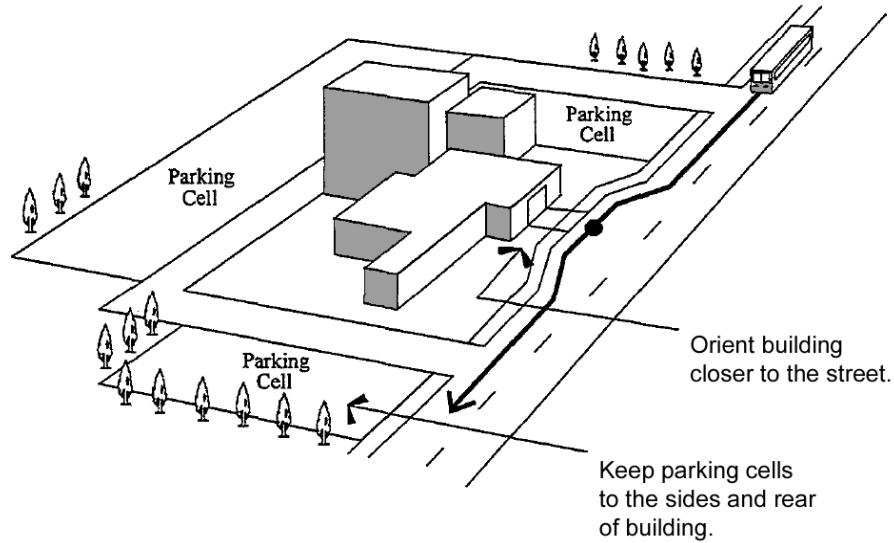

Figure 6 - Orienting the building closer to the street and locating parking to the side or rear.

Source: Volusia County MPO.

Positives:

- Transit passenger walking time and distance is reduced since the building is near the road.
- Improves accessibility for persons with disabilities.
- Patron security is enhanced by having indirect surveillance from the building and passing vehicular traffic.
- Potential for pedestrian/vehicular conflicts are reduced between the land use and the bus stop.
- Potential for shared use of the building facilities, such as overhangs and atriums, by bus patrons during inclement weather.
- Bus remains on main route by eliminating the need to deviate into a parking lot.

Negatives:

- Challenges traditional land use practices, which may make communities more reluctant to implement such a strategy.
- Confusion may develop concerning responsibilities for the maintenance and upkeep of a bus stop that is near a major generator of activity.



Figure 7 - Expanding facility

Source: Transit Cooperative Research Program, Report 19: Guidelines for the Location and Design of Bus Stops, Texas Transportation Institute, Texas A&M Research Foundation, Texas A&M University, College Station, TX, National Academy Press, Washington, D.C., 1996.

Positives:

- Bus vehicle remains on a main thoroughfare.
- Pedestrian access to bus stop is enhanced by juxtaposing building with bus stop and having pedestrian promenades.
- Bus patron comfort is enhanced by the addition of shade trees along the promenade and the installation of a covered walkway between buildings.
- Reduces bus patron exposure to poor weather.

Negatives:

- Pedestrian improvements are costly to construct.
- Requires coordination among many different "players."
- Orientation of new building and parking may challenge traditional land use practices.

4. Minimize walking distance

- Develop a fine-grained street network.

Most people will not walk more than $\frac{1}{4}$ mile to use transit. Therefore, care should be taken to promote the development of a fine-grained street network that minimizes walking distances within transit corridors. Long blocks should be avoided. Where long blocks are unavoidable, mid-block pedestrian pathways should be provided.

- Provide direct pedestrian walkways between key points on site.

Pedestrian connections linking building entrances and services should be provided. Landscaped areas should be carefully designed so as not to disrupt direct pedestrian travel and to avoid isolating pedestrians waiting for buses.

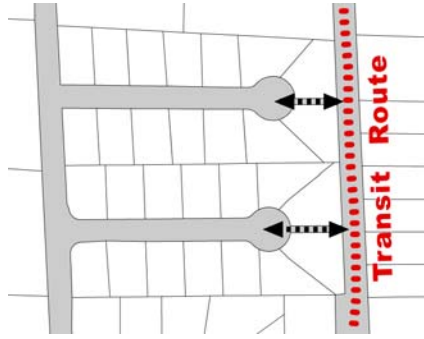

Figure 8a - Preferred; direct pedestrian access to transit

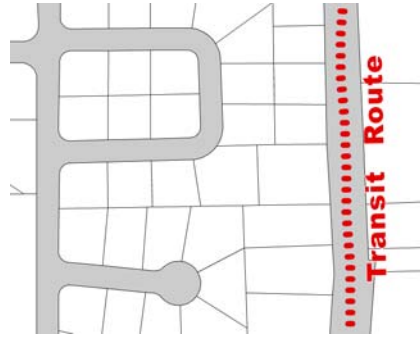

Figure 8b - Not acceptable; no pedestrian access to transit

- Provide sidewalks on both sides of every street.

Generally, available right-of-way width will limit the width of sidewalks; however, where pedestrian volumes are expected to be higher, sidewalks should be wider. To the extent possible, they should be free of utility poles, street furniture, landscaping and other obstructions. As a minimum, they must comply with ADA requirements.

- Provide safe street crossings at all intersections.

Street crossings should be provided at every intersection, and should be designed to accommodate pedestrians with disabilities. Shortening the curb radii will reduce the pedestrians' crossing distance. It will also force turning vehicles to slow, thereby improving pedestrians' safety. However, a curb radius should not be so tight that it will cause buses and other large vehicles to cross into an opposing traffic lane when negotiating the turn.

- Pathways should be used to supplement the normal street network, not replace it.

A pathway should be used only when the street network does not provide a direct route. Pathways should be short, direct and well-lighted. Layout and design of the pathways should maximize opportunities for community surveillance (use principles of "crime prevention through environmental design" - CPTED)

5. Create a pedestrian friendly environment

- The pedestrian system should provide for a continuous high quality barrier free walking surface and be directly linked to stops.
- Pathways should be used to supplement the normal street network, not replace it. Pathways should be short, direct and lighted. Layout and design of the pedestrian network should maximize opportunities for community surveillance.
- The most successful pedestrian streetscapes are characterized by buildings located close to and oriented toward the sidewalk, trees, shop windows, street parking, appropriate sidewalk width, a boulevard, good lighting levels, and, where appropriate, street furniture.
- All network links should comply with ADA requirements.

6. Route into the community

- The transit circulation for large-scale projects should provide for direct transit service through the center of the project (Figure 9a), rather than around the periphery (Figure 9b). This will generally maximize coverage while minimizing travel time.

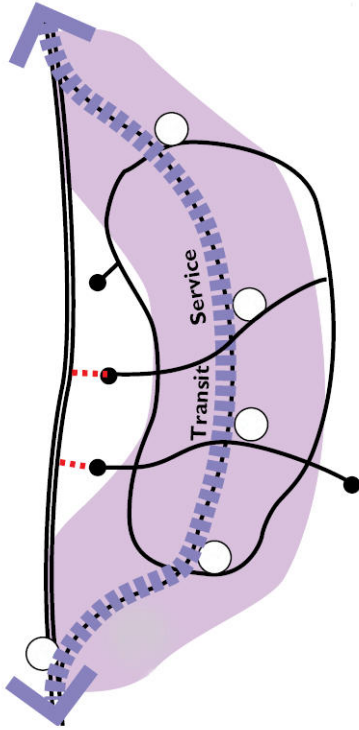

Figure 9a - Direct Central Routing (Preferred)

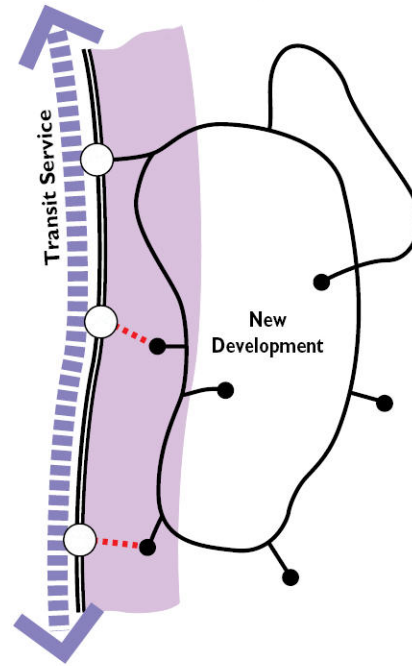

Figure 9b - Peripheral Routing

Source: Central Florida Mobility Design Manual, prepared by Glatting Jackson Kercher Anglin Lopez Rinehart, Inc., in association with Herbert Halback and Assoc., Inc., for Lynx, the Central Florida Transportation Authority, 2000.

7. Reduce transit travel time

Shortening the duration of a transit trip is key to improving service and attracting more riders. Factors directly related to the duration of the transit trip include time walking to and from the transit stop, time waiting for the transit vehicle, and time in the vehicle. If a transfer is needed, there is also additional walking and waiting time.

- Discontinuous street patterns may make it difficult to walk to transit service even though the lineal or cross country distance may be reasonable. Consideration should be given to a pattern of residential streets or walkways that enhance the sidewalk system to provide multiple access routes for both motorist and pedestrians. Where short-cutting traffic may be a problem, the grid should be modified to discourage vehicle traffic while maintaining efficient pedestrian routes.
- New development should provide for the extension of efficient transit service. Routing should be direct and continuous. Double-back routing should be avoided. Where preliminary phases of multi-phased development will not include completion of the transit route, consideration should be given to how transit service will be provided on an interim basis. Temporary bus turnaround facilities or short sections of roadway appropriate for bus use are common techniques to provide transit linkage.

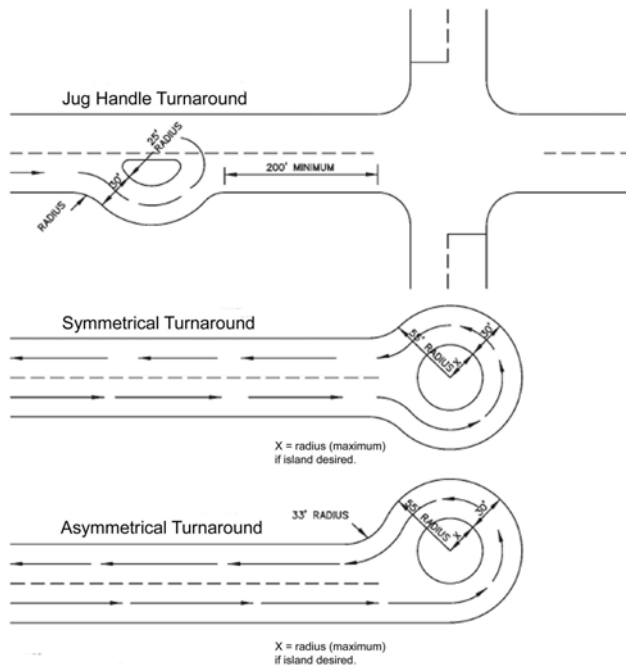

Note: 30' lane width assumes no parking in loop area.
Scale: NTS

Figure 10 - Alternative Bus Turnarounds

Source: JTA Mobility Access Program Handbook, Jacksonville Transit Authority, 2003.

8. Build quality, user friendly transit facilities

- Transit facilities cannot be “second best” or “good enough”.
- Transit facilities must be designed and maintained with respect for transit customers to overcome traditional negative images. Transit facilities should be designed to make transit riders feel welcome and valued. Facility design and signage must also address passenger safety and security, comfort and mobility requirements.

RESIDENTIAL LAND USE PRINCIPLES

1. Density

- Moderately high density (>8 dwelling units per acre) are needed for optimum transit operations.
- Highest density should be located nearest transit routes; most people will not walk more than ¼ mile to use transit, and as a general rule, all dwellings should be within ¼ mile walking distance of a transit stop.

2. Network Connectivity

- A fine-grained, interconnected street network linking adjacent developments/neighborhoods facilitates walking and bicycling.
- Arterial and collector streets should allow efficient movement of buses through and between subdivisions/neighborhoods to reach within ¼ mile of residences within the ridership area; road geometrics should reflect the design limitations of buses.

- Sidewalk system should be continuous.
- Use of cul-de-sacs should be minimized; where unavoidable, well-lighted pedestrian paths should be used to extend continuity.
- Where sound barrier walls or security walls separate a development or neighborhood from a transit route, pedestrian passage should be provided at moderately spaced intervals.

3. Transit facilities

- Shelters, benches and other rider amenities should be provided at transit stops; stops can be located adjacent to neighborhood parks, retention areas or other public or common areas where they will be less intrusive than they might be in someone's front yard. Parks, retention areas or other public areas should be located with consideration to where transit stops will be needed.

RETAIL SHOPPING CENTER LAND USE PRINCIPLES

1. Mix of Uses

- A complimentary mix of retail and service uses should be provided offering the possibility of "chaining" trips.
- Low-intensity auto-oriented uses like automobile sales and services, building supply stores, drive-in /drive-through businesses, and mini-warehouses should be discouraged.

2. Building Design and Orientation

- Street-oriented buildings should be set close to the street to form an "outdoor room" with an optimal street width (measured between building faces) to building height ratio of 1-to-2 or 1-to-3.
- Main entrances should face the street; building façades should be transparent (many windows).
- Awnings should be extended over sidewalks to protect pedestrians from rain and heat.
- Parking should be located behind street-facing buildings; for existing strip shopping centers with parking in front, new "out-buildings" can be added along the sidewalk.

3. Network Continuity

- Continuous sidewalks wide enough to comfortably accommodate higher pedestrian volume; minimize driveways crossing sidewalks; safe street crossings at intersections.
- Larger, more important retail centers (and medical and educational facilities) may incorporate transit stops on-site.

4. Parking

- Abundant free parking should be discouraged; developers should be permitted to reduce parking when developments will support transit use.

OFFICE LAND USE PRINCIPLES

1. Building Design and Orientation

- Street-oriented buildings should be set close to the street to form an "outdoor room" with an optimal street width (measured between building faces) to building height ratio of 1-to-2 or 1-to-3.
- In office parks, buildings should be clustered at intersections with main entrances oriented toward the streets.
- Larger buildings (greater than 25,000 sq. ft.) should have in-lobby waiting areas for transit users.



Figure 11 - Street Oriented Buildings

Source: JTA Mobility Access Program Handbook, Jacksonville Transit Authority, 2003.

2. Network Continuity

- Continuous sidewalks wide enough to comfortably accommodate higher pedestrian volume; minimize driveways crossing sidewalks; safe street crossings at intersections.

3. Parking

- Abundant free parking should be discouraged; developers should be permitted to reduce parking when developments will support transit use.

MIXED USE LAND USE PRINCIPLES

1. Parking

- Abundant free parking should be discouraged; developers should be permitted to reduce parking when developments will support transit use.

VEHICLE CHARACTERISTICS

Votran operates a fleet of passenger transport vehicles ranging from standard passenger vans to 30- and 35-ft. long buses. Characteristics of the various vehicles are specified in Table 3. Dimensions of the most commonly used vehicle -- the 35-ft. bus -- are shown in Table 4.

To ensure the best possible service, VOTRAN recommends that new developments be designed to accommodate all of VOTRAN's passenger transport vehicles whenever possible. The height, weight, turning radius, ground clearance, overhang and other characteristics of VOTRAN's passenger transport vehicles must be considered when designing roads and roadside improvements. Design that properly reflects these vehicle characteristics will result in greater safety, efficiency and passenger comfort.

Table 3 - Vehicle Specifications

Vehicle Type	Length	Height	Turning Radius	Ground Clearance	Vehicle Weight Rating/Curb Weight
35 ft.	36'	10'1"	36'	14-1/2"	39,600/28,160 lbs
35 ft. low floor	36'	9' 8"	36'	13-1/2"	38,700/26,200 lbs
30 ft.	29'11"	9' 8"	29.9"	13-1/2"	31,000/21,775 lbs
Trolley	37' 8"	11' 4"	38'	14"	31,000 lb/21,000 lbs
Para-transit	22' 25'	10' 10'	22'5" 25'5"	13" 13"	14,050/10,600 lbs 14,050/11,300 lbs

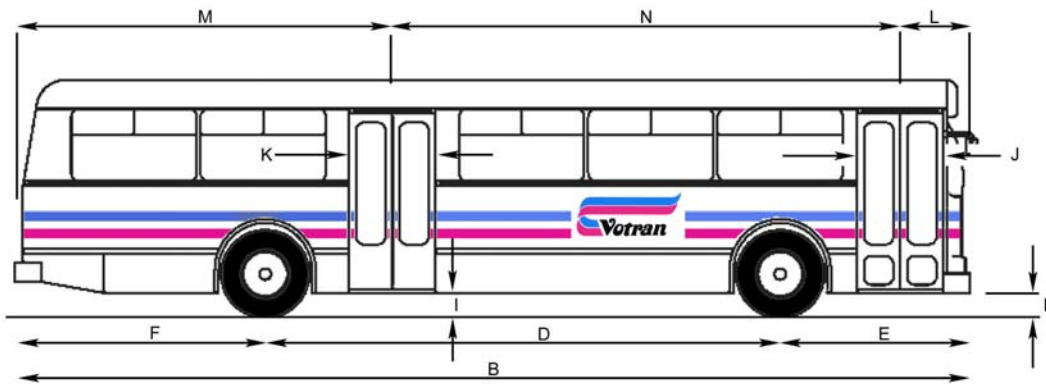

Figure 12a - 35-ft. Standard Bus (side view)

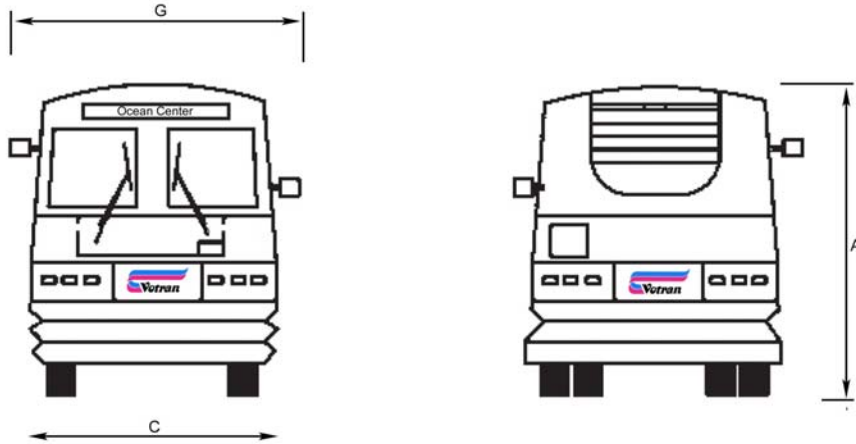

Figure 12b - 35-ft. Standard Bus (front & rear views)

Table 4 - 35-ft. Standard Bus Dimensions

Item		
A	Overall Height	9' 8"
B	Overall Length	36'
C	Overall Width	8' 6"
D	Wheel Base	23' 9"
E	Front Axle to Bumper	7' 3-3/4"
F	Rear Axle to Bumper	9' 4-3/4"
G	Mirror to Mirror (outside edges)	10' 2"
H	Step to Ground (front entry door)	1' 3"
I	Step to Ground (rear exit door)	1' 4-1/2"
	Wheel Chair Ramp Size	31" x 47-1/2"
J	Clear Door Opening (front entry door)	3' 4" x 6' 8"
K	Clear Door Opening (rear exit door)	2' 10" x 6' 8"
L	Centerline Door to Front	3' 0"
M	Centerline Door to Rear	17' 11-1/4"
N	Centerline Door to Door	19' 8"

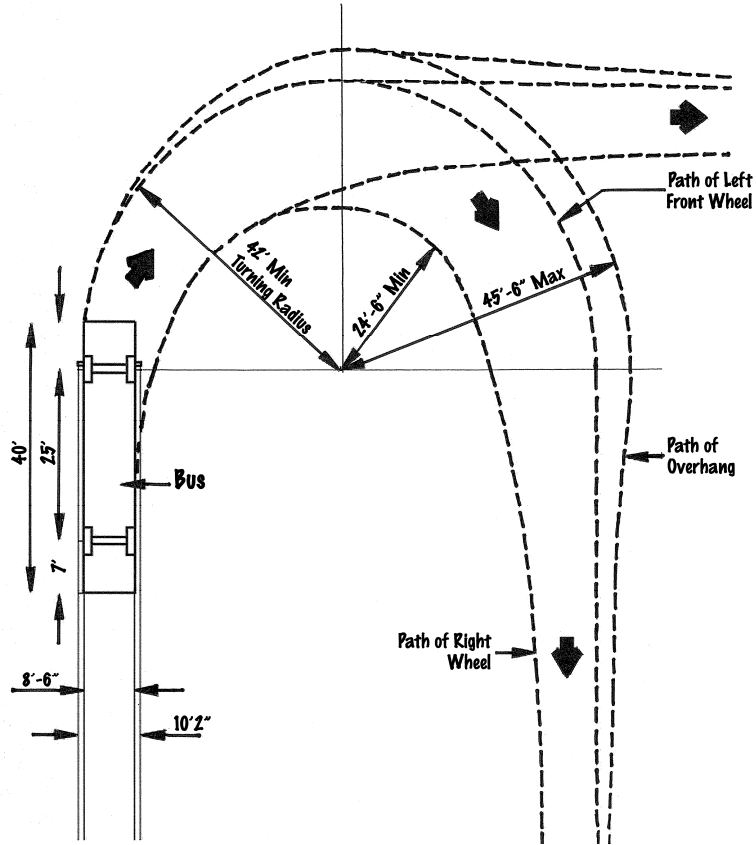

Figure 13 - Standard Bus Turning Template

Source: [Accessing Transit: Design Guidelines for Florida Bus Passenger Facilities](#), Report Prepared for: Florida Department of Transportation, Public Transit Office By: Florida Planning and Development Lab, Department of Urban and Regional Planning, Florida State University, March 2004.

ROADWAY DESIGN

Roadway Characteristics

Roadway width, grade, pavement design and curb detail are important considerations for the safe and efficient maneuvering of transit vehicles. The actual dimensions of vehicles should be used to establish minimum functional street-side standards for transit operations. Vehicle lengths, widths, heights, as well as operating characteristics, should be coordinated with roadway and facility designs. Two types of buses are commonly used by VOTRAN: standard buses (used for most "fixed-route" transit service) and mini-buses used most commonly to provide paratransit service.

Lane Width

For both public and private roadways that accommodate transit vehicles, a 12-foot lane width is preferred to allow proper maneuverability.

Roadway Grade

Roadway grades should be based on bus performance characteristics for grade ascents or descents under fully loaded conditions. A sharp rise and fall of a roadway grade, sometimes referred to as a "crest", can cause a bus to "bottom-out". A similar condition known as "sag" occurs where a road surface depression is so severe that it can leave a bus suspended or "hung-up" on its front and rear overhangs beyond the respective axles. Crests and sags are most likely to occur where a driveway crosses a sidewalk or joins a street.

Curb Height

Low or absent curbs make boarding and alighting more difficult for passengers. Higher curbs may interfere with wheelchair lifts. The optimum curb height is about 6 inches.

Intersection Radii

The radius of a street intersection should be designed to allow buses to turn at appropriate operating speeds without "jumping" the curb line or encroaching into adjacent traffic lanes. When determining intersection radii, consideration should be given to the angle of intersection, transit vehicle turning radii, number and width of roadway lanes and vehicle operating speeds. It may be acceptable for transit vehicles to encroach into adjacent lanes, particularly on local streets where traffic volumes low and vehicle operating speeds are slow.

Intersection radii requirements for a standard 40-foot-long bus are presented in Figure 13 and Table 5, below.

For the paratransit vehicles, the turning radii requirements are:

- minimum interior radius = 37 feet,
- minimum outer radius = 60 feet,

Additional turning radii will be required under the following conditions:

- buses turning at speeds greater than 10 mph,
- buses making reverse turns,
- turns in areas with sight distance limitations,
- turns involving changes in pavement grade,
- turns in areas which restrict the movement of the bus overhang, and
- buses equipped with bike racks.

Driveways from major traffic generators (greater than 400 vehicles per day), or those with significant bus traffic, should be designed as street intersections.

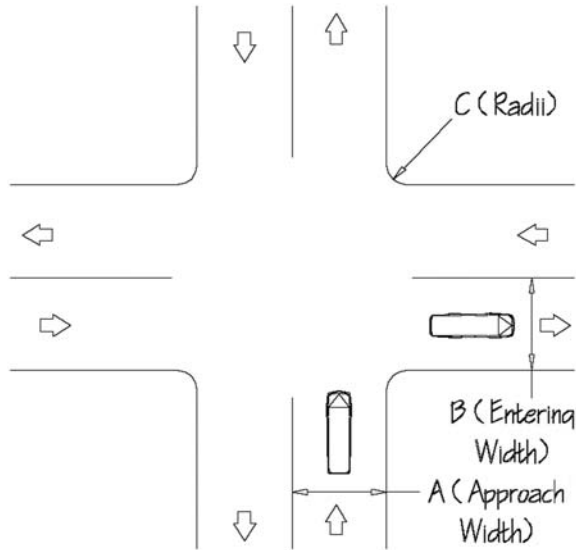

Figure 14 - Lane Width and Curb Radii Specifications

Source: [Accessing Transit: Design Guidelines for Florida Bus Passenger Facilities](#), Report Prepared for: Florida Department of Transportation, Public Transit Office By: Florida Planning and Development Lab, Department of Urban and Regional Planning, Florida State University, March 2004.

Table 5 - Lane Width and Curb Radii Specifications

A Approach Lane Width	B Entering Lane Width	C Curb Radius
12 ft (1 lane)	12'	50'
	16'	45'
	20'	40'
	24'	35'
16 ft (1 lane with 4-foot shoulder)	12'	45'
	16'	40'
	20'	30'
	24'	25'
20 ft (1 lane with parking)	12'	40'
	16'	35'
	20'	30'
	24'	25'

Vertical Clearance

On any route used for bus travel, a 14' 6" minimum clearance must be maintained between the traveled surface and any overhead obstruction.

CLASSIFICATION OF TRANSIT STOPS

VOTRAN classifies transit stops for the purpose of assigning standards appropriate for the type of transit service and rider activity supported by the stops. The classification includes the following facility types:

- Local Stop
- Secondary Stop
- Primary Stop
- Park-and-Ride
- Inter-Modal Transportation Center

The classification of a stop is generally determined by the anticipated passenger volume and the number of transportation modes and routes which converge at the site. Passenger volume is influenced by many variables, including the type, density and intensity of nearby land uses and the accessibility of the site from nearby land uses.

The elements appropriate for each facility type are described below. Site conditions, VOTRAN's operational plans, budgetary constraints and other factors may preclude use of all elements at each stop.

VOTRAN and the local government responsible for development approval will have to determine on a case-by-case basis what combination of elements will work best.

At the "high end" of the transit stop hierarchy are transit terminals, inter-modal facilities and other facilities that must accommodate high volumes of passengers transferring between buses and other transportation modes. These facilities are not addressed here because they are usually designed by engineers and architects with advanced understanding of the complex design requirements.

Local Bus Stop

Local bus stops have the lowest passenger boarding/alighting volumes (generally less than 20 per day) and account for the vast majority of stops on VOTRAN's fixed-route transit system. They are generally located in residential areas or low activity areas.

Secondary Bus Stop

Secondary bus stops are transit stops that have 20 to 49 boardings per day, and are associated with high activity areas. Examples of high activity areas include the Volusia County Administration Building (Deland), Big Box Retail Stores and local hospitals.

Primary Stop

Primary stops, with 50 or more boardings per day, have sufficient passenger activity to warrant a higher level of improvement than is typical with local and secondary bus stops. These stops will generally be needed where concentrations of residents or employees results in moderately high volume throughout the daily period of transit service or higher peak period volume. They may also be needed at points where passengers transfer between routes. Pedestrian connections should provide direct, convenient access from building entrances to loading areas. Primary stops include Dunlawton Square Shopping Center, Market Place Shopping Center and Volusia Mall.

Park-and-Ride

Park-and-ride lots intercept traffic flowing through a commuter shed toward a major employment destination. They may be combined with other kinds of bus passenger facilities. Park-and-ride facilities may also serve as collector sites for vanpools and car pools. A commuter drop-off facility is part of a park-and-ride facility where commuters who are passengers in non-transit vehicles are dropped off to board a transit vehicle.

Inter-Modal Transportation Center

The inter-modal transportation center combines all the elements of design (service and operation) with infrastructure (street side and curbside) to link multiple forms of transportation (walking, bicycle, automobile, bus, rail, and boat).

BUS STOP SITING AND DESIGN

Bus Stop Spacing

As a determinant of convenient access to transit, bus stop spacing is a major factor in a person's decision to use the transit system. Spacing also has a direct bearing on the efficient operation of a transit system.

Shortening the distance between bus stops will reduce walking distance and encourage bus ridership; but will slow bus travel times as the number of stops is increased. These competing interests -- rider convenience and operating efficiency -- must be balanced. Available right-of-way, density of the surrounding catchment area, existing and potential ridership in the area, traffic conditions, and route operations/efficiency should all be considered in the spacing of stops.

In high-density urban areas (major employment centers and/or with population densities greater than or equal to 2,000 persons per square mile), bus stops ideally should be spaced at intervals no more than one-quarter mile and no less than 600 feet along each route.

In less dense suburban areas (with population densities below 2,000 persons per square mile), bus stops ideally should be spaced at intervals no more than one-half mile and no less than one-quarter mile. While these spacing standards are the general rule, exceptions may be made in special circumstances (for example, to accommodate customers with disabilities who might otherwise need to use Votran's fixed route service because they would not be able to access the existing nearest bus stops).

In rural areas, bus stops should be located at local origin or destination points, not necessarily at regular intervals.

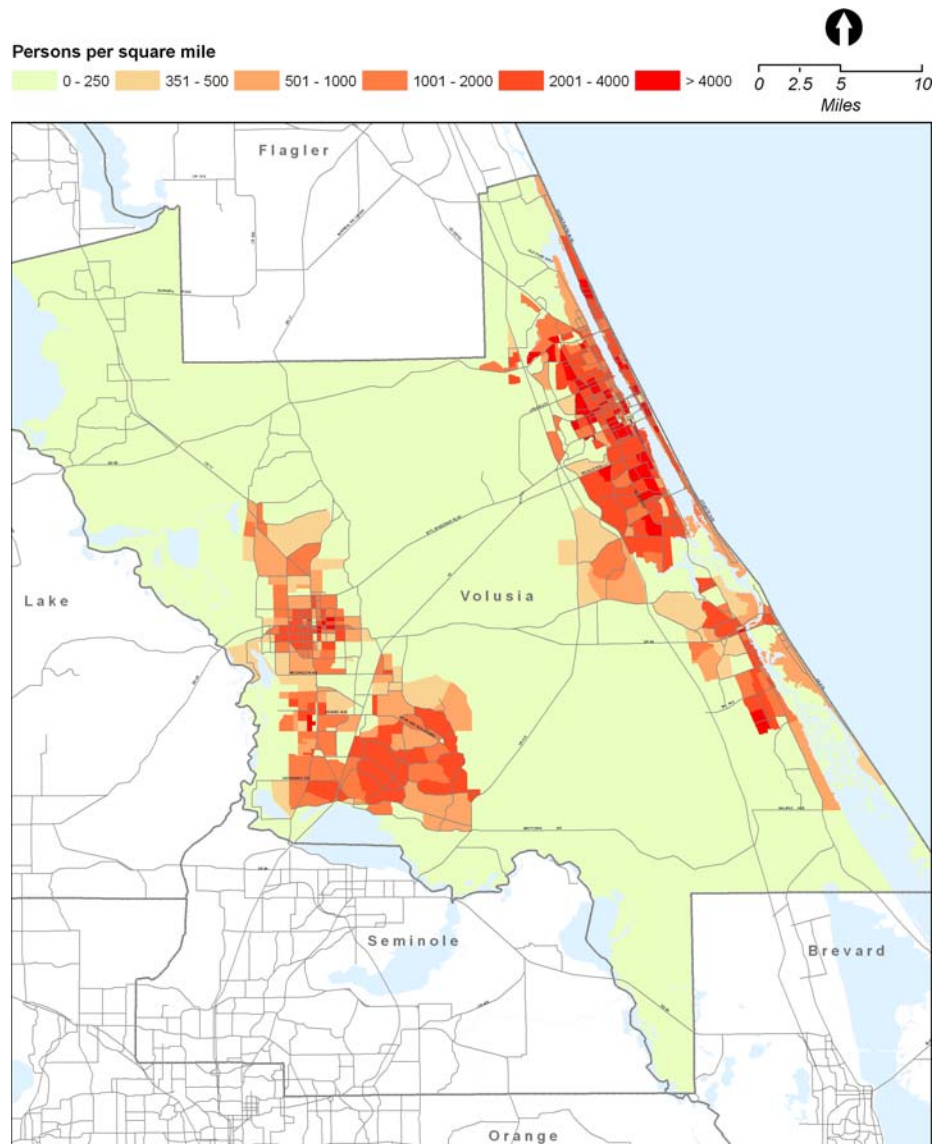

Figure 15 - Population Density by Traffic Analysis Zone, Volusia County 2000

Source: Volusia County MPO and 2000 Census of Population.

Table 6 - Optimum Bus Stop Spacing

Area Type	Miles	Feet
High-density Urban Areas	0.1 to 0.25 miles	528 to 1320 feet
Suburban Areas	0.25 to 0.38 miles	1,320 to 2,000 feet
Rural Areas	at intersections or landmarks	

Placement (Relationship to Land Use/Development)

The actual location of bus stops can influence the convenience of transit access, which, in turn, can impact ridership. Votran's large buses cannot maneuver safely and efficiently through most parking lots. Therefore, Votran's bus stops usually are located on the street (curb-side). Development projects should be designed to accommodate pedestrian traffic between bus stops and building entrances.

Buildings should be located near the street to provide short, direct access between building entrances and bus stops.

Ideally curb-side stops are provided in locations where:

- there is adequate space in the right of way for improvements like shelters or benches.
- access can be provided for passengers with disabilities,
- major trip generators are nearby,
- connections exist to pedestrian facilities,
- nearby intersections are signalized,
- street lighting exists for nighttime routes, and
- adequate curb length is present to accommodate the bus stop zone.

The bus stop location should minimize the need for buses to change lanes before intersections and before approaches to left-hand turns.

Bus stops should be clearly identified with signs to indicate that transit vehicles have exclusive use in the stop area.

The selected location of a bus stop should be chosen to minimize having the stopped buses block driveways. Whenever possible, bus stops should be located beyond driveways to minimize conflicts between buses and other vehicles leaving or entering driveways.

Bus stops should not be located within 30 feet of a rail crossing if no layover period is planned, and within 50-feet of rail crossings if a layover does take place, in order not to obscure railroad warning pavement markings.

Street intersections are usually the best locations for bus stops because higher intensity land development tends to be focused there; and because they are typically are equipped with pedestrian crosswalks, making them easily accessible by pedestrians from a broader area. However, when block lengths are long, mid-block stops may be appropriate to provide shorter, more direct linkages to mid-block land uses.

There are both advantages and disadvantages to the placement of stops at either near side, far side, or mid-block locations. These advantages and disadvantages, along with the land use mix of the area to be served by a bus stop, should be reviewed to ensure a location that will present the most potential riders with the most convenient access, while minimizing traffic congestion and safety concerns.

Far-Side Stops

Far-side bus stops are preferred to nearside stops because they result in fewer traffic delays, provide better vehicle and pedestrian sight distances, and cause fewer conflicts among buses, cars, pedestrians and bicyclists. They are recommended for use under circumstances noted as follows:

- in areas where the right of way permits cars to pass the bus and especially in areas where a near-side stop will impede other motorists,
- where a route alignment requires the bus to turn left before stopping, and
- at complicated intersections with multiphase signals.

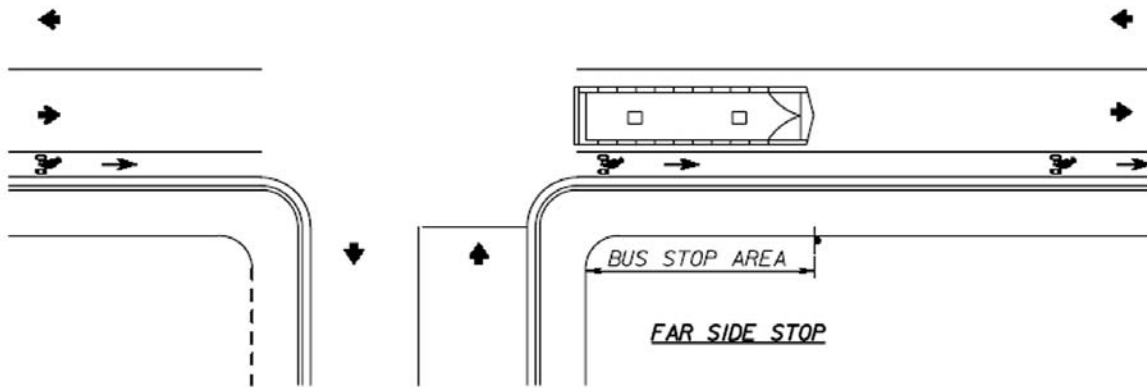

Figure 16 - Far Side Bus Stop

Source: [Transit Facilities Guidelines](#), FDOT Public Transit Office, 2005

Near-Side Stops

Where far-side stops cannot be provided, near-side stops should be located at least 100-feet in advance of the intersection in order to avoid conflicts with vehicles. Use near-side stops on two-lane roads, where vehicles are restricted from going around the bus, in order to prevent the stacking of vehicles in the intersection. Near-side bus stops are also appropriate:

- at prioritized signalized intersections,
- when the bus must stop in the travel lane because of curb-side parking in order for the front door of the bus to access an intersection and crosswalk,
- in combination with curb extensions or bus bulbs to provide direct access from the bus to the sidewalk, and
- in a right turn lane if a queue jump signal is provided to allow the bus to merge back into the travel lane and if accompanied by a sign.

Avoid near-side stops at intersections with dedicated right-hand turn lanes where right-on-red turning is permitted.

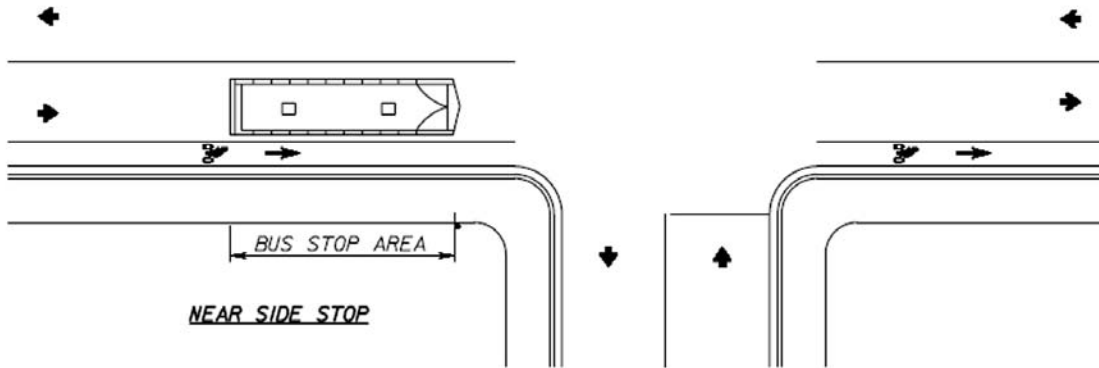

Figure 17 - Near Side Bus Stop

Source: [Transit Facilities Guidelines](#), FDOT Public Transit Office, 2005

Mid-Block Stops

Mid-block stops are generally to be avoided. They are only appropriate when:

- route alignments require a right turn and the curb radius is short,
- the distances between intersections is long,
- major transit generators are located mid-block and cannot be served at the nearest intersection, and
- a marked mid-block pedestrian crossing is present.

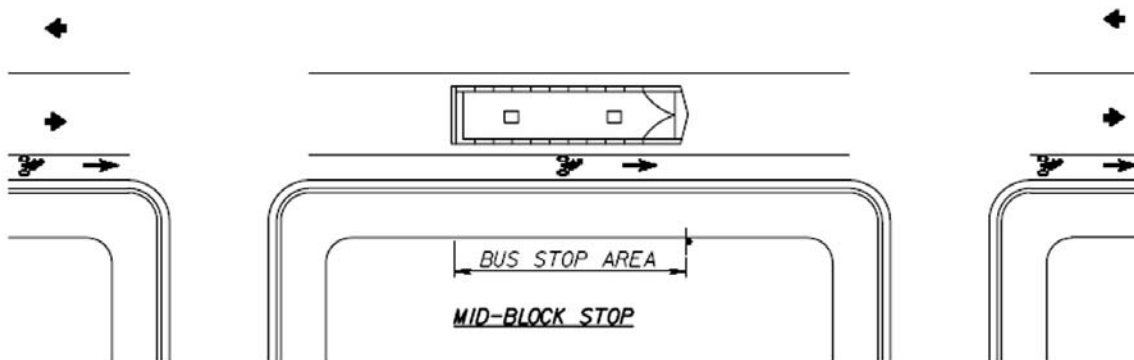

Figure 18 - Mid Block Bus Stop

Source: [Transit Facilities Guidelines](#), FDOT Public Transit Office, 2005

Table 7 - Bus Stop Locations: Advantages and Disadvantages of Location Relative to Street Intersections

Near-Side	
Advantages	Disadvantages
Minimizes interfaces when traffic is heavy on the far side of the intersection.	Conflicts with right-turning vehicles are increased
Passengers access buses closest to crosswalk.	Stopped buses may obscure curbside traffic control devices and crossing pedestrians.
Intersection available to assist in pulling away from curb.	Sight distance is obscured for cross vehicles stopped to the right of the bus.
No double stopping. Buses can service passengers while stopped at a red light.	The through lane may be blocked during peak periods by queuing buses.
Provides driver with opportunity to look for oncoming traffic including other buses with potential passengers.	Increases sight distance problems for crossing pedestrians.
	Pedestrians may cross street in front of bus, unseen by traffic in the left lane.
Far-Side	
Advantages	Disadvantages
Minimizes conflicts between right-turning vehicles and buses.	Intersections may be blocked during peak periods by queuing buses.
Provides additional capacity by making curb lane available for traffic.	Sight distances may be obscured for crossing vehicles.
Minimizes sight distance problems on approaches to intersection.	Increases sight distance problems for crossing pedestrians.
Encourages pedestrians to cross behind the bus.	Stopping far-side after stopping for a red light interferes with bus operations and all traffic in general.
Requires shorter deceleration distances for buses.	May increase number of rear-end accidents since drivers do not expect buses to stop again after stopping at a red light.
Gaps in traffic flow are created for buses re-entering the flow of traffic at signalized intersections.	

Mid-Block	
Advantages	Disadvantages
Minimizes sight distance problems for vehicles and pedestrians.	Requires additional distance for no-parking restrictions.
Passenger waiting areas experience less pedestrian congestion.	Encourages patrons to cross street at mid-block.
Passenger access buses closest to crosswalk.	Increases walking distance for patrons crossing at intersections.
Passengers access buses closest to crosswalk.	Increases walking distance for patrons crossing at intersections.

Source: Accessing Transit: Design Guidelines for Florida Bus Passenger Facilities, report prepared for the Florida Department of Transportation, Public Transit Office, by Florida Planning and Development Lab, Department of Urban and Regional Planning, Florida State University, March 2004.

Curb-Side Bus Stops

Curb-side stops are the most frequently used street-side bus stop facilities. They require no alteration of the roadway; therefore, they can be easily positioned and repositioned. Curb-side stops may be provided where right-of-way is sufficient to allow for placement of benches and shelters, access can be provided for passengers with disabilities, major trip generators are nearby, connections exist to pedestrian facilities, and curb length is sufficient to accommodate the bus stop zone.

Curb-side bus stops should not be used where traffic volumes and speeds are high resulting in conflicts between buses and other traffic.

Figure 19, below illustrates typical curb-side bus stop dimensions. The following can be noted:

- Far-side curb-side bus stops should be a minimum of 90-feet in length.
- Near-side curb-side stops should be a minimum of 100-feet in length.
- Mid-block curb-side stops should be a minimum of 150-feet in length.

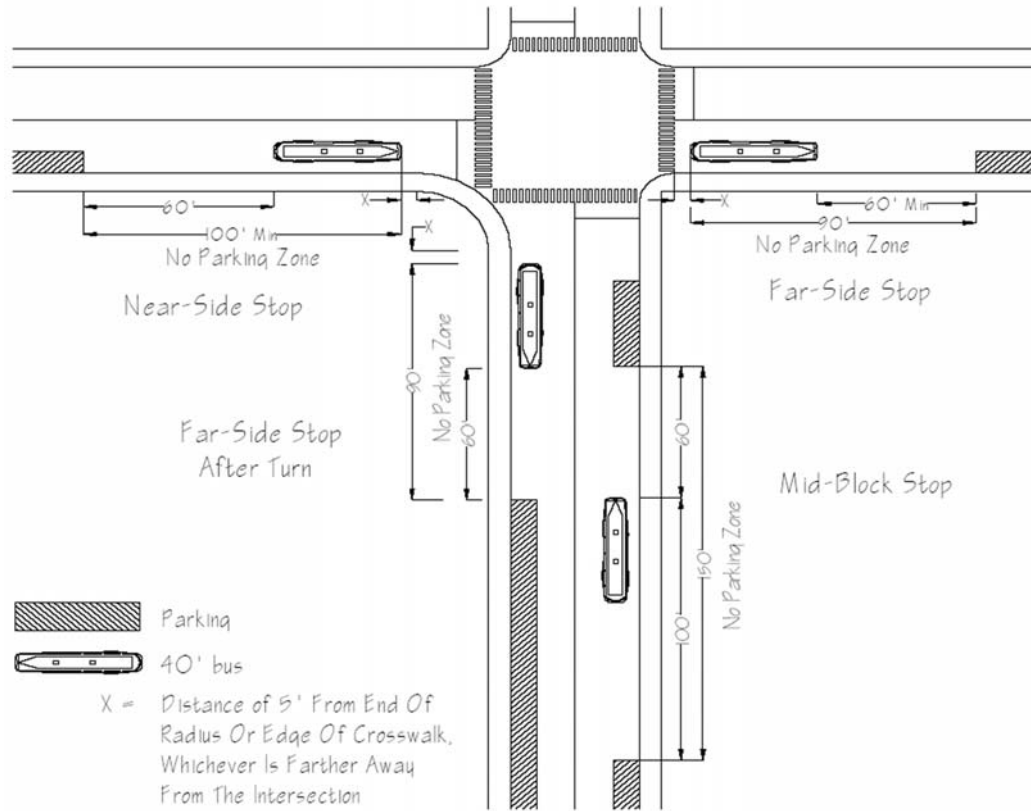

Figure 19 - Dimensions for Various Bus Stop Locations

Source: [Accessing Transit: Design Guidelines for Florida Bus Passenger Facilities](#), Report Prepared for: Florida Department of Transportation, Public Transit Office By: Florida Planning and Development Lab, Department of Urban and Regional Planning, Florida State University, March 2004.

Bus Bays (Pullout or Turnout Bays)

In some situations, bus bays for transit vehicles are appropriate (i.e., consistent slow boarding, layover needs, safety reasons, high speed traffic, etc.). Bus bays can be designed for one or more buses.

Coordination with Votran will help determine the need for and justification of bus bays. They should be located on the far side of a signalized intersection. The traffic signal will create the critical gap needed for bus re-entry into traffic. Acceleration/deceleration lanes should be provided to ease the transition into and out of traffic. Additional design information for transit system applications is available from the FDOT's District Public Transportation Office or on the Internet at <http://www.dot.state.fl.us/transit/>.

Bus Bulbs

Bus bulbs are extensions of the sidewalk into the parking lane. They allow buses to make curbside stops without weaving in and out of the travel lane. They also provide additional space for bus shelters, benches, and signage, shorten the distance pedestrians must cover when crossing a street, and allow bus passengers to move directly from bus to sidewalk without having to cross between parked cars.

Bus bulbs allow buses to hold their place in traffic, thus eliminating waiting time that would otherwise occur when re-entering busy traffic lanes. However, they can also cause vehicles to stack behind stopped buses. Therefore, they should not be used on high-speed (>45 mph) or high-volume roadways where vehicle stacking will be problematic.

Bulbs are best used on the near-side of signalized intersections in areas where buses experience delays in re-entering the traffic lane, where traffic calming is desired, and where traffic volume will be relatively low.

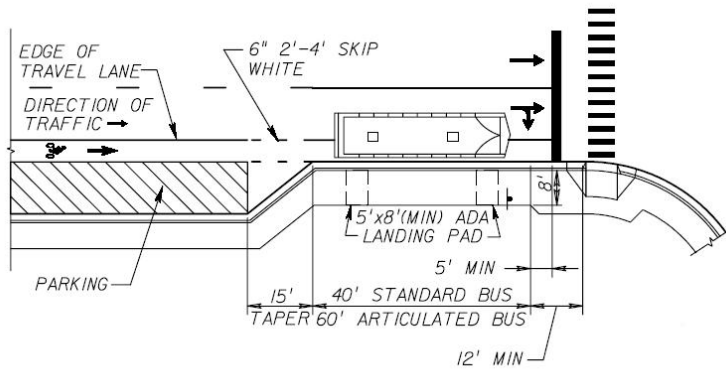

Figure 20 - Near-Side Bus Bulb

Source: Transit Facilities Guidelines, FDOT Public Transit Office, 2005

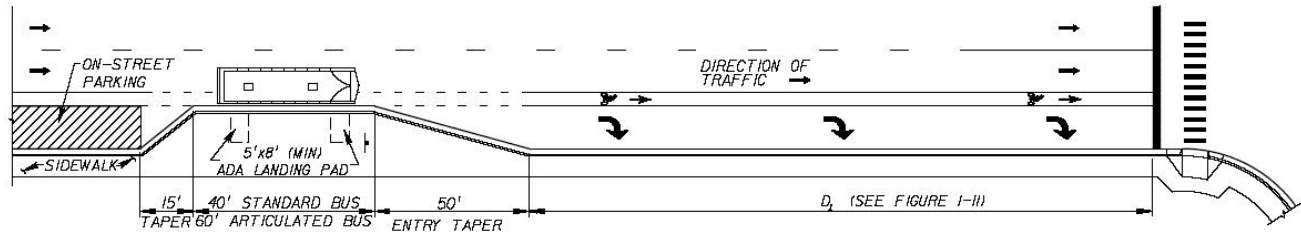

Figure 21 - Mid-Block Bus Bulb

Source: Transit Facilities Guidelines, FDOT Public Transit Office, 2005

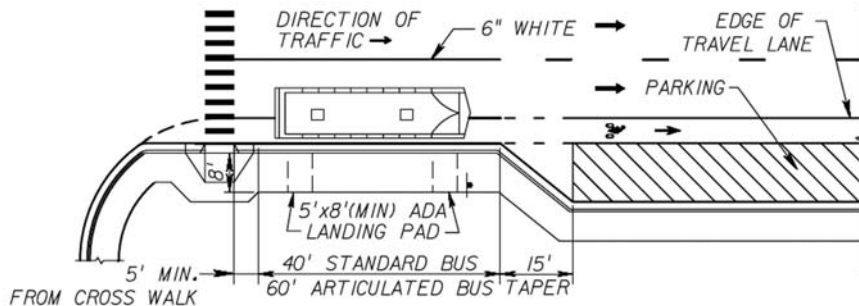

Figure 22 - Far Side Bus Bulb

Source: Transit Facilities Guidelines, FDOT Public Transit Office, 2005

Infrastructure

Votran's goal is to provide all transit patrons with comfortable facilities that provide shelter from the sun, rain and other elements. If transit service is going to compete successfully with other modes of transportation, transit facilities must be designed and maintained with respect for transit customers to overcome traditional negative images. Transit facilities should be designed to make transit riders feel welcome and valued.

Facility design and signage must also address passenger safety and security, comfort and mobility requirements.

Transit patrons should have waiting areas that are outside pedestrian flows yet connected to the pedestrian circulation network and separated and secure from automobile traffic. Bus stop pads should be provided at all bus stops and connectivity to sidewalks should be considered when selecting bus stop locations.

Designing facilities with climate in mind, using renewable energy technologies, and reducing potable water consumption, further enhances bus transit's environmentally friendly profile.

Votran's resources for providing passenger facilities are limited, forcing the agency to make choices. As a result, the transit stops that are most used will generally be given highest priority for improvement.

General infrastructure requirements for transit stops are presented below. For more detailed information, please consult [Accessing Transit: Design Guidelines for Florida Bus Passenger Facilities](#), prepared for: Florida Department of Transportation Public Transit Office, by: Florida Planning and Development Lab, Department of Urban and Regional Planning, Florida State University, March 2004.

Bike Racks at Bus Shelters

Votran recognizes the needs of the inter-modal bicyclist-passenger. While an increasing number of our buses accommodate bicycles with racks mounted at the front of the bus, less has been done to accommodate bicycles at bus passenger facilities. Some bicycle storage facilities offer more security to bike owners than others. For instance, the traditional "comb" bicycle racks do not provide the support for the bicycle's frame or adequate space to secure bikes with a security cable and a "U" lock.

- Bike racks should be placed at bus stops along routes where bus mounted bike racks are at capacity and cannot accommodate more bike passengers without having those passengers wait for the next bus.
- Bicycle storage areas should be placed in defensible spaces that are physically and visually accessible. Placement along heavily trafficked streets and walkways protects bicycles from theft and vandalism.
- Do not locate bike racks and lockers in the corner of a parking garage or in other areas with low visibility.
- Bike lockers and racks should be located near streets with high vehicle and foot traffic to improve visibility.
- To avoid unnecessary water damage to bicycles, do not place bike racks near sprinkling systems.
- Where possible, bicycle racks should be kept underneath a covered area to protect the bikes from exposure to the weather.
- If the bike rack is covered, it should be designed so that nothing can be hidden in the bike rack area.
- Bike racks should support bikes by their frames at two points (as opposed to supporting them by the wheel as common in comb and toast racks). An inverted "U" is a simple effective design to do this.
- Bike racks should provide 48-inch aisles, measured from tip to tip of bike tires across the space between racks or between the tip of the tire and an adjacent obstacle. One person should be able to walk one bike through the aisle.
- Seventy-two inches of depth (6-feet) should be allowed for each row of parked bicycles.
- Racks should be located no less than 24 inches from walls.
- Inverted "U" racks should be placed no less than 36-inches apart widthwise.

Bus Stop Signs

Signs are usually placed to provide references for bus operators and passengers. Important aspects to be considered in placing transit signs are passenger convenience, public safety and bus stop visibility.

- Bus stop signs should be posted at all bus stops and bus passenger facilities.
- Proper horizontal clearance to signposts should be provided. In urban areas the minimum distance from the face of the curb to the bus stop sign is 4-feet. In rural areas the minimum distance is 6-feet.
- Signposts should be located no more than 8-feet from the face of curb in order to be visible to the bus operator
- Bus stop signs must comply with all the applicable requirements set forth in the Manual on Uniform Traffic Control Devices. Bus stop signs should be designed with a uniform size and shape and coordinate with the agency's identity package.
- Signs should clearly display information. When possible, easily understood symbols should be used in lieu of written information.
- Signpost placement should conform to the Americans with Disabilities Act (ADA) clearance requirements for height, sidewalk width, visibility, and other design criteria.
- Signposts at strategic locations, such as those with high passenger volumes or those that act as transfer points between routes, should contain expanded information including schedules in a format that is easy to update and system maps with the bus stop location highlighted.

Bus Benches

Seating, most often in the form of benches, is a very important component in the provision of amenities at the facility site. Benches may be sheltered or unsheltered. Traditionally, many transit agencies including Votran have relied on private advertising vendors to supply unsheltered benches, but as more cities and counties have adopted restrictive sign ordinances, the use of these benches has become problematic if not forbidden.

- Benches should be provided at bus stops used by elderly and disabled persons.
- Benches should be provided at bus stops and transfer locations where either route has headways exceeding 20 minutes.
- Benches should be provided at bus stops located adjacent to properties with features attracting riders to use them for seating (e.g., retaining walls, stairs, and low fences).
- Benches should not be placed near an area where someone could hide or could harm or rob the waiting transit patron.
- Unsheltered benches may be provided in locations where the regular number of riders does not warrant a shelter.
- Benches may be provided in high ridership locations that have weather protection but no seating.
- Unsheltered seating may be provided in high use areas that are unsuitable for shelters because of high levels of pedestrian movement in a small area. Benches should be kept clear of passenger loading and unloading areas, placed no closer than 5-feet and no further than 12-feet from the forward end of any bus stop.
- Proper horizontal clearance to benches should be provided. In urban areas, the minimum distance from the face of the curb to the bench is 4-feet. Bench placement should accommodate passengers' legs and feet without placing them too close to traffic. In rural areas the distance will vary according to the design speed of the road; the higher the roadway speed the further the bench should be placed from the lane.
- Benches should have a minimum clearance of 5-feet at the side and rear to allow persons in wheelchairs to access the bus stop and should not be located on the wheelchair landing pad.

- Benches should allow transit patrons a clear view of the bus.
- If a sidewalk is provided, allow a minimum 3-foot sidewalk clearance for passing pedestrians.
- Benches may not be placed on medians or on limited access roadways.
- Benches should be placed on concrete pads.
- Benches should suggest sitting patterns and number of participants.
- According to Florida law, benches shall not exceed 74-inches in length, 28-inches in depth and 44-inches in height [Florida Administrative Code (FAC), Chapter 14, Rule 14-20.0032 "Placement of Transit Bus Benches"].
- At stops with unsheltered benches, additional waiting room near the bench, sheltered by landscaping, should be provided for standing passengers.
- Benches should not be placed in completely exposed locations. Landscaping should shield customers from the weather. Benches should be placed so that streetlights or other objects do not obscure the visibility of waiting passengers or oncoming buses.
- Two-person benches (4-feet, 2-inches long) can be placed at bus stops with medium ridership levels. These are usually placed inside shelters but can also be freestanding.
- Freestanding, three-person benches can be placed at bus stops with high ridership levels and/or high visibility.
- Benches should discourage opportunities for sleeping or reclining.
- Benches should be located upstream of where the bus will stop, outside the ADA-mandated landing pad.
- Seating should incorporate a platform height of 18-inches to 24-inches.
- Benches without backs allow more flexible double-sided seating arrangements.
- Bench materials should be weather resistant, discourage vandalism, vagrancy and require little maintenance.
- Preference should be given to bus benches composed from recycled materials including high density polyethylene, one of the most popular types of recycled plastic, and rapidly renewable materials like wood.

Bus Stop Leaning Rails

Many passengers prefer leaning to sitting while waiting at bus stops. Leaning rails also provide a place to shelve objects passengers may carry. Transit agencies that have placed leaning rails at their bus shelters claim that they are inexpensive to install and are heavily used by passengers.

- Leaning rails can be located within shelters mounted on walls, be free standing or can be built into the landscape.
- Leaning rails should have a round as opposed to square or rectangular section with a diameter of 1 ½- to 2 ½-inches.
- Freestanding leaning rails should be between 27- and 42-inches in height.
- Leaning rails attached to bus shelters should be no more than 27-inches in height.
- Leaning rails can be sheltered or unsheltered. When unsheltered, landscaping should be provided to shield customers from the weather.
- Leaning rails should be constructed of anodized aluminum in order to enhance their durability.

Bus Stop Trash Receptacles

Trash receptacles should be treated as normal parts of most bus passenger facilities. Maintenance of trash receptacles and trash pick-up is an important consideration when receptacles are provided.

- Trash receptacles cannot be placed on wheelchair landing pads and should be placed in the manner outlined below to comply with the Americans with Disabilities Act.
- Trash receptacles should be located at least 4-feet back from the face of the curb. The receptacles should be anchored to the pavement or landing pad in order to prevent unauthorized movement.
- The receptacles should be placed so that they do not obstruct a driver's vision while turning. If possible, trash receptacles should not be placed in direct sunlight. Direct sunlight exposure may result in odors.
- If vandalism is a concern, trash receptacles with lockable lids or other anti-vandal features should be used.
- If possible, trash receptacle designs should coordinate with benches and other furniture at the bus stop or transfer center in regard to material and finish color. Trash receptacles should be made out of steel with a powder-coat paint finish.

Bus Stop Pads

Bus stop pads provide a well-drained, non-slippery surface with adequate space for amenities and passenger movement on and off buses.

- Bus stop pads should be placed at all bus stops with shelters. It is preferable to provide pads at unsheltered bus stops with benches. The ideal bus stop pad size is 10-feet by 30-feet.
- When the available space for a pad is less than 10-feet by 30-feet, the pad should be as large as possible. Pads may be sized according to the dimensions of the shelter if a shelter is planned for the location. The pad should extend 6-inches beyond the area under the shelter canopy in order to prevent soil erosion caused by runoff.
- Any easement obtained for installing a pad should extend 2-feet beyond the pad.
- Pads for sheltered stops may include conduits and junction boxes for utilities. Bus stop pads should be constructed of reinforced concrete over an aggregate base. The thickness will vary according to the design of the anchoring required for various bus stop elements as affected by expected wind loads.
- Free edges of pavement should be strengthened with reinforcement.

Bus Stop Shelters

Shelters protect waiting passengers from exposure to the sun and rain. The minimal form of a shelter is an overhead canopy beneath which passengers wait for the bus. Optional side enclosures for shelters and the provision of other amenities under or near the shelter enhance the image of the transit service and offer a comfortable and convenient transit trip for patrons. In Florida it is of particular importance to design with the climate in mind. Solar radiation, heavy precipitation, and high relative humidity make waiting for the bus, especially in summer, extremely uncomfortable for passengers. As a result, allowing for shading, shelter, and ventilation are important considerations.

Opportunities also exist to incorporate recycled or renewable materials into shelters and their components. Renewable energy technology, including wind and solar power, can be adapted to provide shelters with electricity for illumination and cooling.

- Bus shelters should be provided at any stop with at least 25 boardings a day.
- Bus shelters should also be provided at stops that are major generators of peak hour transit ridership or are major transfer points between routes. Stops that attract large concentrations of the

young or elderly, such as schools, recreation centers, or senior citizen housing facilities, should be sheltered.

- The open side of a shelter should be placed toward oncoming traffic and should be grade separated from the travel lane.
- Bus shelters should not be placed on medians or on limited access roads.
- Shelters should be located upstream of the bus zone without interfering with passengers boarding and alighting in order to maximize the visibility for approaching buses, passing traffic, and waiting passengers. The location of bus shelters should minimize walking distances for waiting passengers. Shelters should be located at least 5-feet from the front door of the bus along the direction of travel in order to provide adequate circulating space for persons in wheelchairs.
- Proper horizontal clearance to shelters should be provided. In urban areas, the minimum distance from the face of the curb to the bus stop sign is 4-feet. In rural areas the distance will vary according to the design speed of the road.³See FAC, Chapter 14, Rule 14-20.003 and FDOT Design Standards Index 700.
- Shelters should not be placed on sidewalks where they could obstruct the movement of pedestrians. A minimum 3-foot pedestrian pathway should be maintained on three sides of the shelter. In areas with high pedestrian volumes, a 6-foot pathway on one side of the shelter is preferred.
- Do not place shelters on the wheelchair landing pad area required by ADA. The ADA landings must also be completely outside of the shelter interior.
- Shelters should not be located within 15-feet of a fire hydrant or a parking space for the disabled.
- Shelters also should provide a clear opening at their bottoms in order to allow for cleaning and increased security.
- Shelters should not be placed in front of store windows of adjacent properties.
- When a shelter is located in front of a building, a minimum 12-inch space should remain between the building and the shelter to allow for cleaning.
- Orient shelters so that they provide as much protection as possible from sun, wind and rain.
- Access entry points should not have less than 36-inch wide clearance.
- The shelter should have provisions to accommodate elderly and disabled people in order to meet ADA standards. A shelter that is accessible to people in wheelchairs must have a minimum clear floor area 30-inches wide and 4-feet deep entirely within the perimeter of the shelter.
- Shelters should be designed to incorporate benches and/or leaning rails and may also include route maps, transit service literature, telephones, newspaper vending and trash receptacles.
- Shelter designs should allow for additional site furnishings as the need arises.
- When available right of way is limited, it is better to provide a smaller shelter than not to provide a shelter at all.
- The size and design of shelters varies with the number of boardings at a bus stop and with space availability.
- As the first image of the transit system, the shelter should speak to the security of the system.
- Advertising panels, if permitted, should be located in a manner that does not limit visibility, preferably downstream of bus traffic.
- Shelters should allow for unobstructed views into and out of structures. The design of the shelter should not create blind spots or hiding places in order to protect the facility and its patrons from crime.

- The shelter should be designed with adequate illumination for security at night.
- The architecture of the shelter should, where appropriate, be indicative of nearby land uses; it should provide the rider with a means of orientation within the community.
- Shelter canopies should take into account sun and rain protection. Shelters oriented to the southeast and southwest may be uncomfortable for passengers if adequate shade is not provided.
- Shelters should be designed to maximize shading and to encourage cooling air movement. Sun shade protection should exist on all sun-exposed sides of the shelter.
- Impervious side panel materials are poorly suited to Florida's climate. Pervious side panels allow for ventilation.
- Shelters should be designed to require low levels of maintenance. It should be easy to clean the shelters and the concrete landing pad beneath and around the shelters.
- The shelter should be made out of materials that are durable and vandal-resistant.
- Bus shelters should be re-used when possible.
- Preference should be given to incorporating local, recycled or renewable materials into bus shelter designs.
- Preference should be given to using renewable energy technologies.
- Preference should be given to constructing bus passenger facilities surfaces (e.g., shelter canopy, landing pad, and sidewalks) from light-colored, highly reflective materials in order to reduce heat absorption.

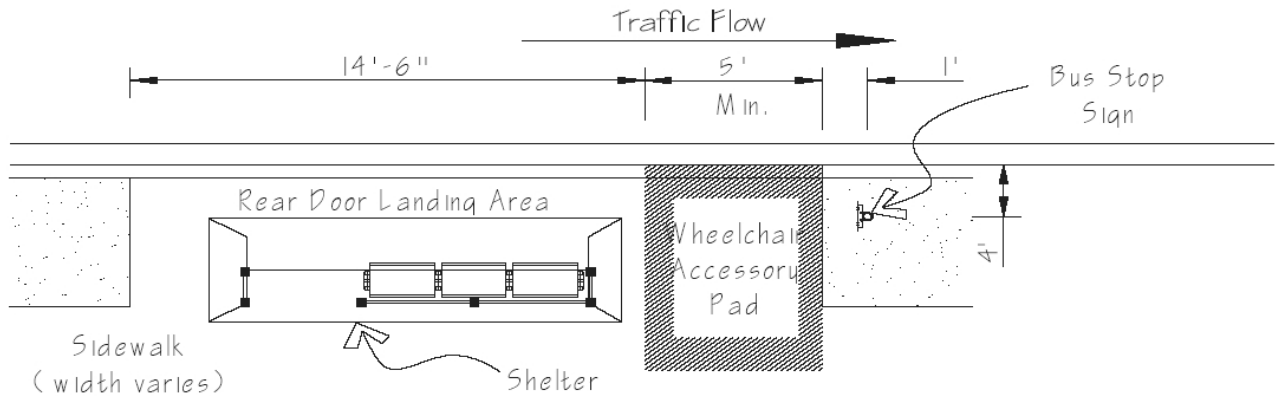

Figure 23a - Alternative configurations of bus stops

Source: [Accessing Transit: Design Guidelines for Florida Bus Passenger Facilities](#), Report Prepared for: Florida Department of Transportation, Public Transit Office By: Florida Planning and Development Lab, Department of Urban and Regional Planning, Florida State University, March 2004.

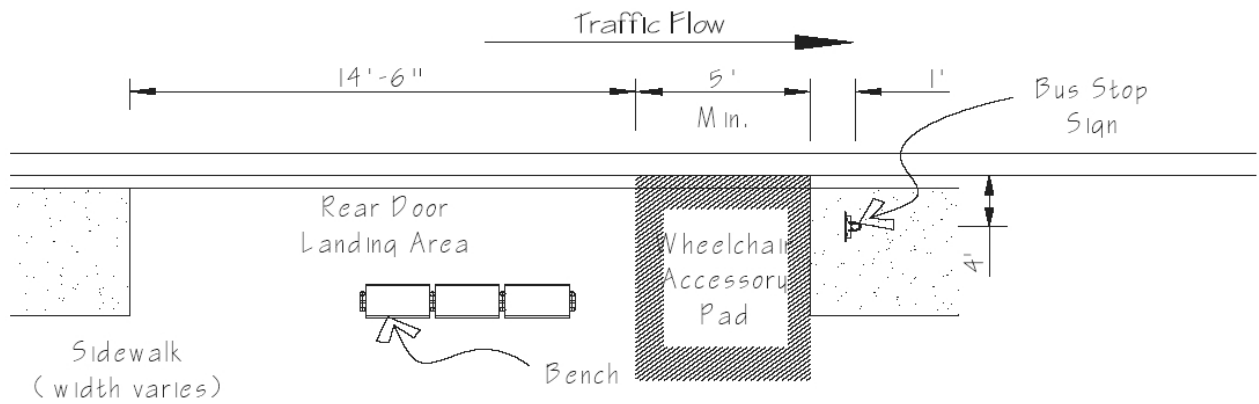

Figure 23b - Alternative configurations of bus stops

Source: [Accessing Transit: Design Guidelines for Florida Bus Passenger Facilities](#), Report Prepared for: Florida Department of Transportation, Public Transit Office By: Florida Planning and Development Lab, Department of Urban and Regional Planning, Florida State University, March 2004.

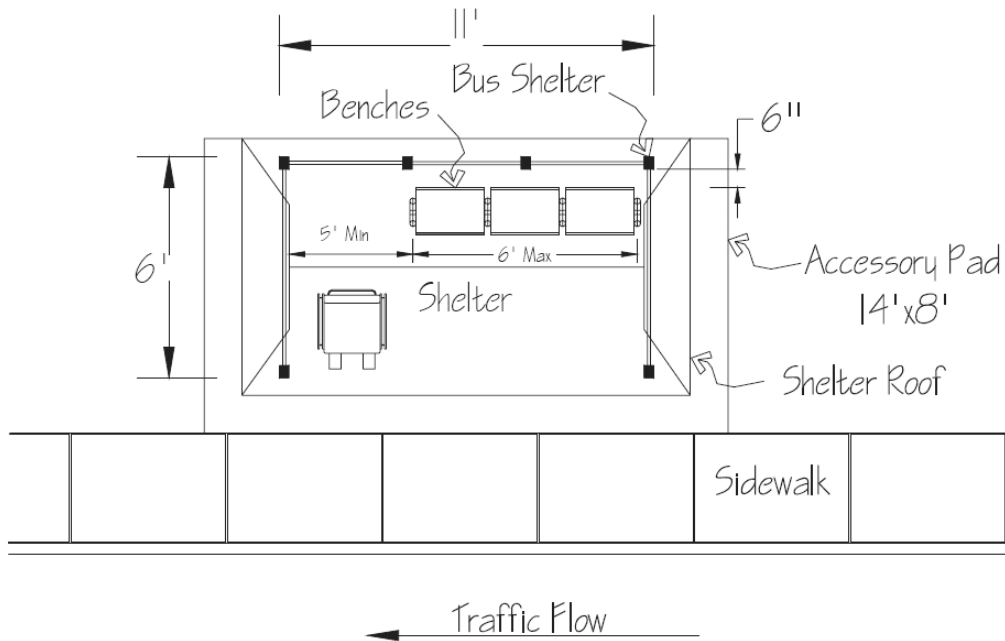

Figure 24 - Typical bus shelter layout and design

Source: [Accessing Transit: Design Guidelines for Florida Bus Passenger Facilities](#), Report Prepared for: Florida Department of Transportation, Public Transit Office By: Florida Planning and Development Lab, Department of Urban and Regional Planning, Florida State University, March 2004.

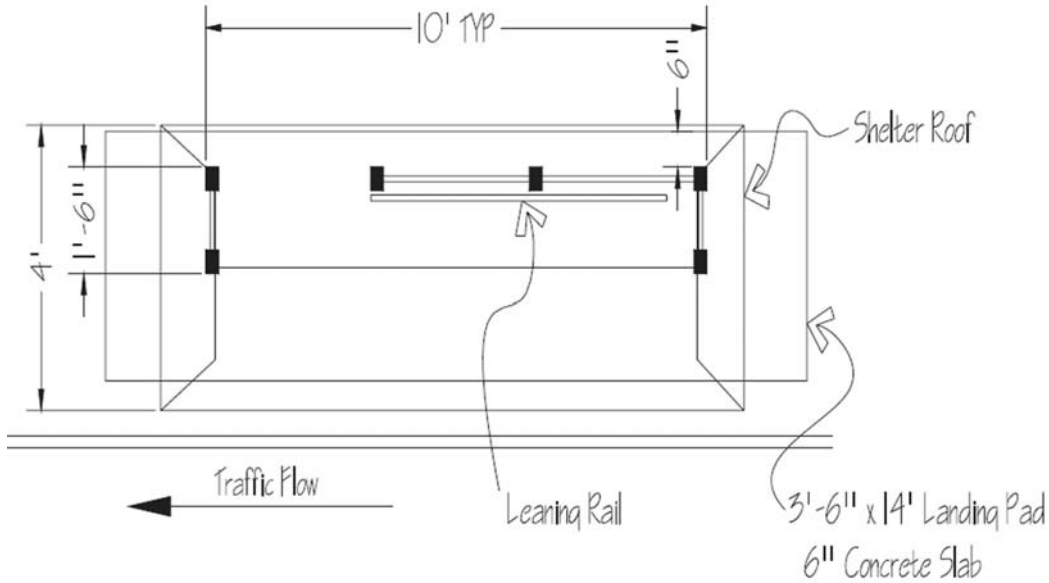

Figure 25 - Typical dimensions of a small bus shelter with a leaning rail but no seating, applicable to stops with limited right of way width

Source: [Accessing Transit: Design Guidelines for Florida Bus Passenger Facilities](#), Report Prepared for: Florida Department of Transportation, Public Transit Office By: Florida Planning and Development Lab, Department of Urban and Regional Planning, Florida State University, March 2004.

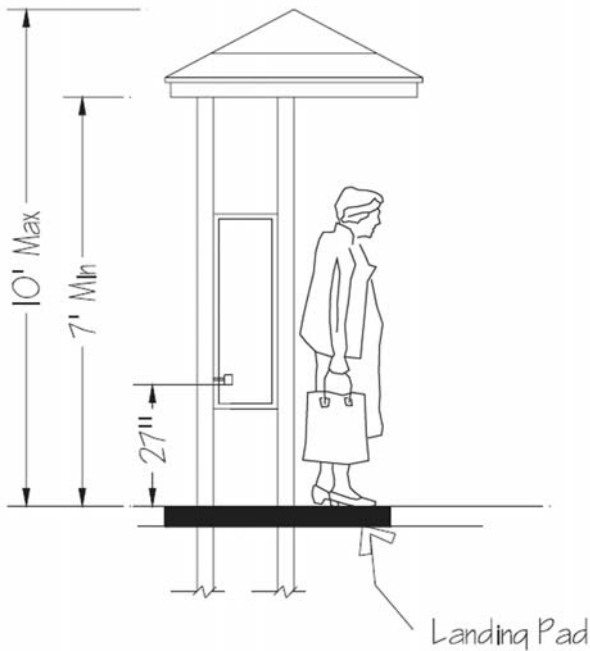

Figure 26 - Cross section of a small bus shelter with a leaning rail but no seating with typical vertical dimensions

Source: [Accessing Transit: Design Guidelines for Florida Bus Passenger Facilities](#), Report Prepared for: Florida Department of Transportation, Public Transit Office By: Florida Planning and Development Lab, Department of Urban and Regional Planning, Florida State University, March 2004.

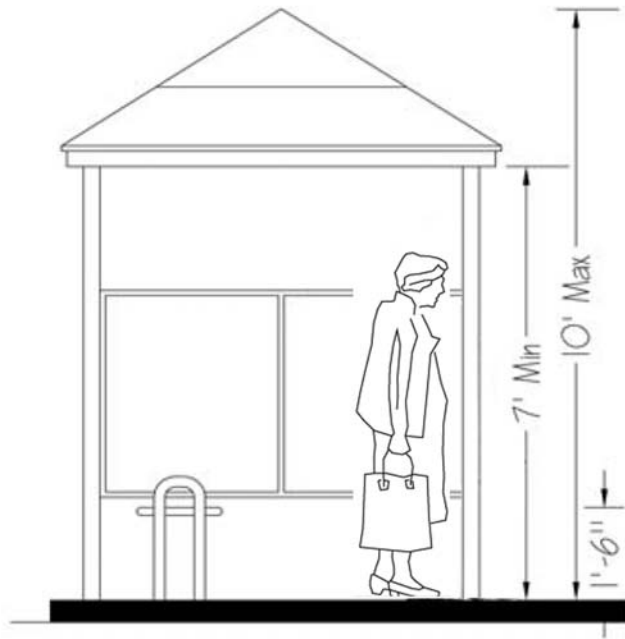

Figure 27 - Cross section of a mid-size shelter with typical vertical dimensions.

Source: *Accessing Transit: Design Guidelines for Florida Bus Passenger Facilities*, Report Prepared for: Florida Department of Transportation, Public Transit Office By: Florida Planning and Development Lab, Department of Urban and Regional Planning, Florida State University, March 2004.

Bus Stop Information and Way-Finding Devices

Providing system maps and fare information at bus passenger facilities is both useful to passengers and provides the transit agency an opportunity to educate passengers and potential passengers about bus transit services.

- Fixed route maps and information should be displayed at all bus stops with high passenger volumes and at stops that serve as transfer points between routes.
- Fixed maps should be sheltered from inclement weather and should be easily visible by passengers.
- Fixed information displays should contain expanded information including schedules in a format that is easy to update. Route maps should highlight bus stop locations.
- Route maps should be easily understandable to transit passengers.
- Route maps may highlight activity centers in order to assist passengers with trip planning.
- The overall design of maps and schedules should also consider the needs of sight and hearing impaired passengers. Bus brochures, bus schedules and other transit literature may be offered at stops and on buses or other transit services.
- Maps and schedules should adopt uniform graphic standards, sizes and color codes.
- Maps and schedules should be as intelligible as possible to an international audience in areas where there is a significant visitor population.
- Solar or wind-powered on-demand illumination is suggested for bus stop information and way-finding devices.

Bus Stop Shelter Hurricane Wind Loads

Bus shelters are prone to damage and may become sources of flying debris if they are not adequately anchored, sized and fabricated to resist high wind speeds. The Florida Building Code has minimum requirements to ensure that bus shelters in hurricane-prone areas can withstand high winds and the impacts of wind-borne debris.

- As defined in the Florida Building Code, bus shelters must be properly anchored to the ground. Designers must consider uplift against the force of gravity by hurricane force winds.
- The Florida Building Code also indicates that bus shelters must be fabricated to withstand exterior wind pressures. In wind-borne debris regions (areas of 120 mph and above), all exterior coverings must be made of shatter-resistant materials.

Landscaping

Landscaping at bus stops promotes transit ridership by enhancing its image. Landscaping also contributes to the safety, security, and comfort of passengers. Landscaping can be used to reduce heat islands (thermal gradient differences between developed and undeveloped areas), minimizing the facilities impact on the microclimate. Drought tolerant plants should be used whenever possible to reduce or eliminate the need to irrigate, thus conserving water resources.

- Landscaping should be located so that it buffers waiting passengers from traffic and provides them some degree of protection from the weather.
- Landscaping should not block the view of patrons from outside the bus stop.
- In order to maintain a defensible space, the height of groundcover plants should not exceed 2-feet at maturity so that visibility is preserved for patrons.
- Also in order to maintain a defensible space, the height of shrubs should not exceed 3-feet at maturity, so that visibility is preserved for patrons.
- In combination with groundcovers and trees pruned up to 6-feet above ground, shrubs should be used between 6-feet and 12-feet from the edge of walkways requiring visual surveillance.
- When river-rock and other masonry materials are used, the material should be grouted to prevent removal by hand. River-rock should be grouted so that only one-third of the rock is exposed above ground.
- In order to ease maintenance and to ensure the longevity of plant materials use native plants and wild flowers. In landscapes installed in coastal areas plants should also be salt tolerant. Avoid the use of exotic plant species.
- All landscaping along FDOT rights of way must comply with the latest edition of the Plans Preparation Manual (PPM) and the Florida Highway Landscape Guide (<http://www.dot.state.fl.us/emo/beauty/landscap.pdf>), and the FDOT Design Standards Index 546 and 700.6
- Whenever landscaping will be installed, it is important to coordinate with the state or local agency assigned the responsibility of maintaining it.
- Efforts should be made to shade all constructed surfaces. Shade trees should be high branching so that they do not interfere with breezes. Low vegetation should not block air movement beneath the shelter.
- When irrigation is necessary, the use of high efficiency irrigation systems, low-water use native plants, or the reuse of storm water or gray water for irrigation is should be promoted.

Bus Stop Shelter Lighting

The purpose of lighting is to enhance the safety of patrons at facilities by illumination and to illuminate passenger information and advertising where applicable. In order to reduce light pollution, lighting should be

designed to eliminate light trespass from the bus passenger facility, improving night sky access, and reducing nuisance glare on adjacent properties and within the roadway.

- Bus passenger facilities along routes that offer nighttime or after dark services should have optimum levels of lighting incorporated in the design of the facility. Adequate lighting greatly influences actual safety and passengers' perception of safety, especially at off-street facilities.
- Lighting levels should be sufficient to provide customers with a sense of security while they wait for buses. Adequate lighting also enables the bus driver to see waiting passengers and to safely approach and depart from a bus stop.
- The minimum level of lighting at shelter pavement should be 2.0-foot-candles but "over" lighting should also be avoided.
- Local transit stops can be located under existing overhead light sources.
- Light patterns should concentrate light at the shelter while minimizing overthrow of glare onto street. For road lighting installations, light near and above the horizon should be minimized to reduce glare and visual intrusion. Lighting specifically designed to minimize the upward spread of light should be used.
- Cutoff luminaires, low-reflectance surfaces, and low-angle spotlights can be employed to reduce light pollution.
- If pedestrian paths adjacent to transit stops are illuminated, the height of the light fixture should be appropriately scaled.
- Light fixtures should be visually non-obtrusive so as not to attract the attention of vandals.
- The fixtures should be vandal-resistant and durable.
- Lamp compartment and electrical access areas should be secured with a recessed hex head screw or equal means.
- If possible, electrical services should be low voltage to reduce the risk of electrical shock.
- Solar lighting is suggested in areas where there is currently no utility service or as a temporary measure until utilities can be established for the shelter or stop. Portable solar lighting may be used when transit service is detoured during construction projects.

ADA Accessibility

The Americans with Disabilities Act of 1990 (ADA) is broad legislation intended to make American society more accessible to people with disabilities. It consists of five sections or titles (employment, public services, public accommodations, telecommunications, and miscellaneous). Titles II and III (public services and public accommodations) affect bus stop planning, design, and construction. Although the definition of disability under the ADA is broad, bus stop placement and design most directly affect persons with mobility and visual impairments. These impairments, which relate to the more physical aspects of bus stop accessibility, have received the most attention.

All new stops should be designed and constructed in conformance with ADA physical dimension requirements. Modifying existing stops to comply with ADA, though desirable from an accessibility perspective, is not required under ADA. Modification of existing stops may be difficult, especially if the stops are at sites with limited easement or not subject to the transit agency's control, such as shopping malls, on state rights-of-way, or suburban subdivisions.

The ADA, however, is concerned with more than physical dimensions. It also involves accessibility from the point of origin to the final destination. For example, to get to the bus stop, individuals with limited mobility or vision need a path that is free of obstacles, as well as a final destination that is accessible. A barrier-free bus stop or shelter is of little value if the final destination is not accessible. Though the ADA does not require retrofitting transit vehicles with lifts, an accessible vehicle is clearly a critical link in the barrier-free trip. Full accessibility is more difficult to achieve when different organizations are responsible for different portions of

the path (which is usually the case). Either way, the "equal access" provisions of the ADA require that the route for persons with limited mobility or vision be as accessible as the route used by those without disabilities. A person with disabilities should not have to travel further, or use a roundabout route, to get to a designated area.

Basic Principles for Bus Stop Design and Location to Conform to ADA Basic aspects of design exist that encourage accessibility and are applicable to most situations. Specific dimensions are available from several references, some of which are listed below. Some general design considerations involve obstacles, surfaces, signs, and telephones.

Obstacles

Examine all the paths planned from the alighting point at the bus stop to destinations off the bus stop premises. Determine whether any protrusions exist that might restrict wheelchair movements. If protrusions exist and they are higher than 27 inches or lower than 80 inches, a person with a vision impairment may not be able to detect an obstacle (such as a phone kiosk) with a cane. A guide dog may not lead the person with the impairment out of the path. Although it may not be the transit agency's responsibility to address accessibility problems along the entire path, an obstacle anywhere along the path may make it inaccessible for some transit users with disabilities.

Surfaces

Surfaces must be stable, firm, and slip-resistant. Such provisions are beneficial for all transit users, but especially for those who have disabilities. Avoid abrupt changes in grade, and bevel those that cannot be eliminated. Any drop greater than 1/2 inch or surface grade steeper than 1:20 requires a ramp.

Signs

Signs providing route designations, bus numbers, destinations, and access information must be designed for use by transit riders with vision impairments. Specific guidelines are given for these signs in Section 4.30 of Accessibility Guidelines for Buildings and Facilities, Transportation Facilities and Transportation Vehicles. In some cases, two sets of signs may be needed to ensure visibility for most users and to assist users with sight limitations. Route maps or timetables are not required at the stop, though such information would be valuable to all passengers.

Telephones

Telephones at bus stops are not required under ADA, but if telephones are in place, they must not obstruct access to the facility and must be suitable for users with hearing impairments. At least one phone must be accessible for wheelchair users. Telephone directories must also be accessible.

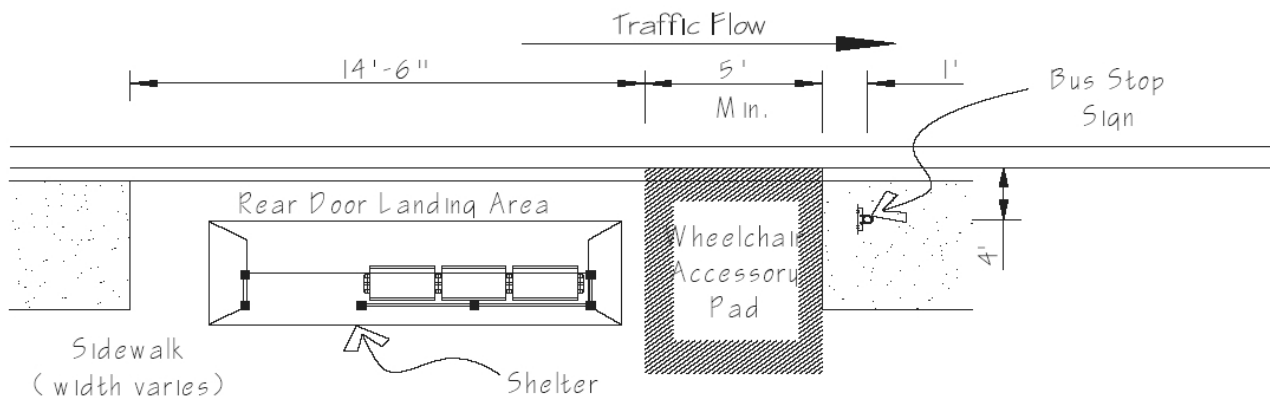

Figure 28a - Typical Bus Stop Layout with Shelter

Source: Accessing Transit: Design Guidelines for Florida Bus Passenger Facilities, Report Prepared for: Florida Department of Transportation, Public Transit Office By: Florida Planning and Development Lab, Department of Urban and Regional Planning, Florida State University, March 2004.

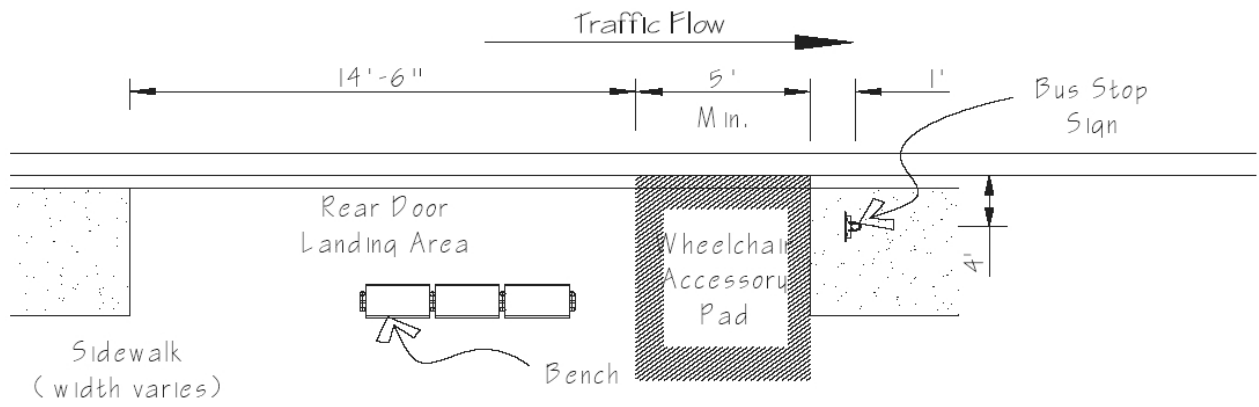

Figure 28b - Typical Bus Stop Layout without Shelter

Source: [Accessing Transit: Design Guidelines for Florida Bus Passenger Facilities](#), Report Prepared for: Florida Department of Transportation, Public Transit Office By: Florida Planning and Development Lab, Department of Urban and Regional Planning, Florida State University, March 2004.

Table 8 - Bus Stop Location Criteria and System Character

	Local Stop	Secondary Stop	Primary Stop	Park and Ride	Intermodal Transportation Center
Criteria Used to Designate Bus Stop					
Land is available (either in or adjacent to right-of-way)	✓	✓	✓	✓	✓
Accessible by pedestrians	✓	✓	✓	✓	✓
Meets ADA accessibility requirements	✓	✓	✓	✓	✓
Passes Votran safety evaluation	✓	✓	✓	✓	✓
Requested by customers	✓	✓			
Recommended by bus operator	✓	✓			
Large development trip generator			✓		
Passenger volume is anticipated to be 60 to 99 per day		✓	✓		
Passes Votran operational evaluation (routing design and turning requirements)					
Passenger volume is anticipated to be less than 40 boardings per day	✓				
Passenger volume is anticipated to be 40 to 79 boardings per day		✓			
Passenger volume is anticipated to be 80 or more boardings per day			✓		
General System Characteristics					
Uniformly spaced and located in residential areas	✓				
Closely spaced in downtown areas and activity centers		✓			
More distantly spaced (1/2 to 1 mile) in rural areas and adjacent to identified origin or destination	✓				
Medium to high density/intensity land use (commercial or mixed uses in retail activity center)		✓	✓		
Transfer activity between routes		✓	✓		
Accessible by way of a well developed bike/pedestrian network		✓	✓		✓

Table 9 - Bus Stop Improvement Standards

	Local Stop	Secondary Stop	Primary Stop	Park and Ride	Intermodal Transportation Center
Improvements					
Transit sign	■	■	■	■	■
Paved pad	□	■	■	■	■
Passenger shelter	□	■	■	■	■
Route/fare information	⊗	□	■	■	■
Seating	□	□	■	■	■
Leaning rail	□	□	□	□	□
Trash receptacle	⊗	□	■	■	■
Newspaper rack	⊗	⊗	□	□	□
Lighting	□	■	■	■	■
Public telephone	⊗	□	□	□	□
Bicycle storage	⊗	□	■	□	■
Information kiosk	⊗	⊗	□	□	■
Bus bay	⊗	□	■	■	■
Reader board	⊗	⊗	⊗	□	□
Drinking fountain	⊗	⊗	⊗	⊗	⊗
Restrooms	⊗	⊗	⊗	⊗	⊗
Automobile parking	⊗	⊗	⊗	■	■

Key: ✓ - does apply; ■ - recommended improvements; □ - conditional improvement (sometimes appropriate, depending on conditions/location); ⊗ - discouraged improvement

Appendix A - ADA Accessibility Guidelines for Buildings and Facilities

[An excerpt from Appendix A to Part 1191 - Americans with Disabilities Act (ADA) Accessibility Guidelines for Buildings and Facilities]

10. TRANSPORTATION FACILITIES.

10.1 General. Every station, bus stop, bus stop pad, terminal, building or other transportation facility, shall comply with the applicable provisions of section 4, the special application sections, and the applicable provisions of this section.

10.2 Bus Stops and Terminals.

10.2.1 New Construction.

(1) Where new bus stop pads are constructed at bus stops, bays or other areas where a lift or ramp is to be deployed, they shall have a firm, stable surface; a minimum clear length of 96 inches (measured from the curb or vehicle roadway edge) and a minimum clear width of 60 inches (measured parallel to the vehicle roadway) to the maximum extent allowed by legal or site constraints; and shall be connected to streets, sidewalks or pedestrian paths by an accessible route complying with 4.3 and 4.4. The slope of the pad parallel to the roadway shall, to the extent practicable, be the same as the roadway. For water drainage, a maximum slope of 1:50 (2%) perpendicular to the roadway is allowed.

(2) Where provided, new or replaced bus shelters shall be installed or positioned so as to permit a wheelchair or mobility aid user to enter from the public way and to reach a location, having a minimum clear floor area of 30 inches by 48 inches, entirely within the perimeter of the shelter. Such shelters shall be connected by an accessible route to the boarding area provided under paragraph (1) of this section.

(3) Where provided, all new bus route identification signs shall comply with 4.30.5. In addition, to the maximum extent practicable, all new bus route identification signs shall comply with 4.30.2 and 4.30.3. Signs that are sized to the maximum dimensions permitted under legitimate local, state or federal regulations or ordinances shall be considered in compliance with 4.30.2 and 4.30.3 for purposes of this section.

EXCEPTION: Bus schedules, timetables, or maps that are posted at the bus stop or bus bay are not required to comply with this provision.

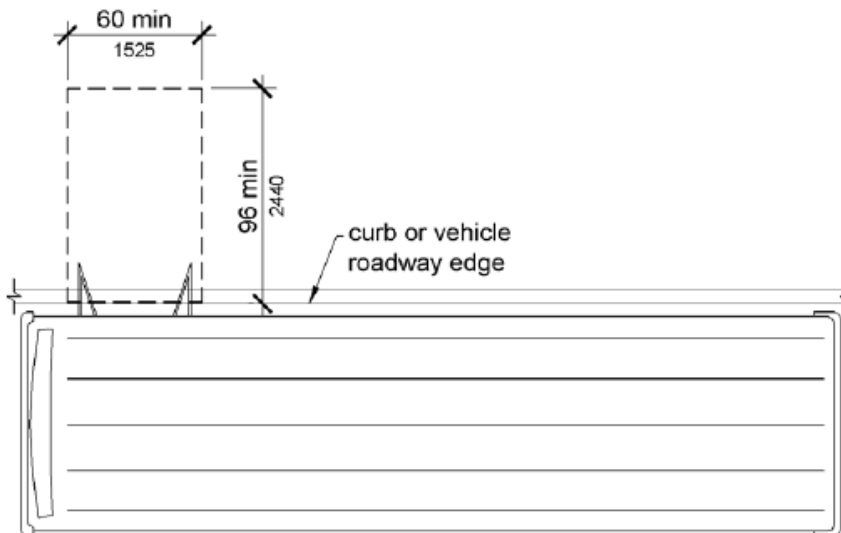

Figure 29 - Dimensions of Bus Boarding and Alighting Areas

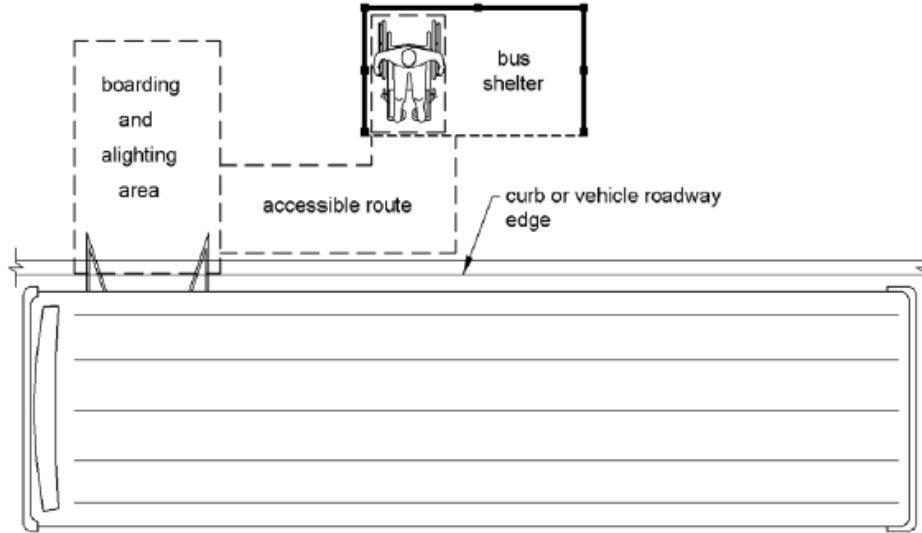

Figure 30 - Bus Shelters

10.2.2 Bus Stop Siting and Alterations.

- (1) Bus stop sites shall be chosen such that, to the maximum extent practicable, the areas where lifts or ramps are to be deployed comply with section 10.2.1(1) and (2).
- (2) When new bus route identification signs are installed or old signs are replaced, they shall comply with the requirements of 10.2.1(3).

10.3 Fixed Facilities and Stations.

10.3.1 New Construction. New stations in rapid rail, light rail, commuter rail, intercity bus, intercity rail, high speed rail, and other fixed guideway systems (e.g., automated guideway transit, monorails, etc.) shall comply with the following provisions, as applicable:

- (1) Elements such as ramps, elevators or other circulation devices, fare vending or other ticketing areas, and fare collection areas shall be placed to minimize the distance which wheelchair users and other persons who cannot negotiate steps may have to travel compared to the general public. The circulation path, including an accessible entrance and an accessible route, for persons with disabilities shall, to the maximum extent practicable, coincide with the circulation path for the general public. Where the circulation path is different, signage complying with 4.30.1, 4.30.2, 4.30.3, 4.30.5, and 4.30.7(1) shall be provided to indicate direction to and identify the accessible entrance and accessible route.
- (2) In lieu of compliance with 4.1.3(8), at least one entrance to each station shall comply with 4.14, Entrances. If different entrances to a station serve different transportation fixed routes or groups of fixed routes, at least one entrance serving each group or route shall comply with 4.14, Entrances. All accessible entrances shall, to the maximum extent practicable, coincide with those used by the majority of the general public.
- (3) Direct connections to commercial, retail, or residential facilities shall have an accessible route complying with 4.3 from the point of connection to boarding platforms and all transportation system elements used by the public. Any elements provided to facilitate future direct connections shall be on an accessible route connecting boarding platforms and all transportation system elements used by the public.
- (4) Where signs are provided at entrances to stations identifying the station or the entrance, or both, at least one sign at each entrance shall comply with 4.30.4 and 4.30.6. Such signs shall be placed in uniform locations at entrances within the transit system to the maximum extent practicable.

EXCEPTION: Where the station has no defined entrance, but signage is provided, then the accessible signage shall be placed in a central location.

(5) Stations covered by this section shall have identification signs complying with 4.30.1, 4.30.2, 4.30.3, and 4.30.5. Signs shall be placed at frequent intervals and shall be clearly visible from within the vehicle on both sides when not obstructed by another train. When station identification signs are placed close to vehicle windows (i.e., on the side opposite from boarding) each shall have the top of the highest letter or symbol below the top of the vehicle window and the bottom of the lowest letter or symbol above the horizontal mid-line of the vehicle window.

(6) Lists of stations, routes, or destinations served by the station and located on boarding areas, platforms, or mezzanines shall comply with 4.30.1, 4.30.2, 4.30.3, and 4.30.5. A minimum of one sign identifying the specific station and complying with 4.30.4 and 4.30.6 shall be provided on each platform or boarding area. All signs referenced in this paragraph shall, to the maximum extent practicable, be placed in uniform locations within the transit system.

(7)* Automatic fare vending, collection and adjustment (e.g., add-fare) systems shall comply with 4.34.2, 4.34.3, 4.34.4, and 4.34.5. At each accessible entrance such devices shall be located on an accessible route. If self-service fare collection devices are provided for the use of the general public, at least one accessible device for entering, and at least one for exiting, unless one device serves both functions, shall be provided at each accessible point of entry or exit. Accessible fare collection devices shall have a minimum clear opening width of 32 inches; shall permit passage of a wheelchair; and, where provided, coin or card slots and controls necessary for operation shall comply with 4.27. Gates which must be pushed open by wheelchair or mobility aid users shall have a smooth continuous surface extending from 2 inches above the floor to 27 inches above the floor and shall comply with 4.13. Where the circulation path does not coincide with that used by the general public, accessible fare collection systems shall be located at or adjacent to the accessible point of entry or exit. Appendix Note

(8) Platform edges bordering a drop-off and not protected by platform screens or guard rails shall have a detectable warning. Such detectable warnings shall comply with 4.29.2 and shall be 24 inches wide running the full length of the platform drop-off.

(9) In stations covered by this section, rail-to-platform height in new stations shall be coordinated with the floor height of new vehicles so that the vertical difference, measured when the vehicle is at rest, is within plus or minus 5/8 inch under normal passenger load conditions. For rapid rail, light rail, commuter rail, high speed rail, and intercity rail systems in new stations, the horizontal gap, measured when the new vehicle is at rest, shall be no greater than 3 inches. For slow moving automated guideway "people mover" transit systems, the horizontal gap in new stations shall be no greater than 1 inch.

EXCEPTION 1: Existing vehicles operating in new stations may have a vertical difference with respect to the new platform within plus or minus 1-1/2 inches.

EXCEPTION 2: In light rail, commuter rail and intercity rail systems where it is not operationally or structurally feasible to meet the horizontal gap or vertical difference requirements, mini-high platforms, car-borne or platform-mounted lifts, ramps or bridge plates, or similar manually deployed devices, meeting the applicable requirements of 36 C.F.R. part 1192, or 49 C.F.R. part 38 shall suffice.

(10) Stations shall not be designed or constructed so as to require persons with disabilities to board or alight from a vehicle at a location other than one used by the general public.

(11) Illumination levels in the areas where signage is located shall be uniform and shall minimize glare on signs. Lighting along circulation routes shall be of a type and configuration to provide uniform illumination.

(12) Text Telephones: The following shall be provided in accordance with 4.31.9:

(a) If an interior public pay telephone is provided in a transit facility (as defined by the Department of Transportation) at least one interior public text telephone shall be provided in the station.

(b) Where four or more public pay telephones serve a particular entrance to a rail station and at least one is in an interior location, at least one interior public text telephone shall be provided to serve that entrance. Compliance with this section constitutes compliance with section 4.1.3(17)(c);.

(13) Where it is necessary to cross tracks to reach boarding platforms, the route surface shall be level and flush with the rail top at the outer edge and between the rails, except for a maximum 2-1/2 inch gap on the inner edge of each rail to permit passage of wheel flanges. Such crossings shall comply with 4.29.5. Where gap reduction is not practicable, an above-grade or below-grade accessible route shall be provided.

(14) Where public address systems are provided to convey information to the public in terminals, stations, or other fixed facilities, a means of conveying the same or equivalent information to persons with hearing loss or who are deaf shall be provided.

(15) Where clocks are provided for use by the general public, the clock face shall be uncluttered so that its elements are clearly visible. Hands, numerals, and/or digits shall contrast with the background either light-on-dark or dark-on-light. Where clocks are mounted overhead, numerals and/or digits shall comply with 4.30.3. Clocks shall be placed in uniform locations throughout the facility and system to the maximum extent practicable.

(16) Where provided in below grade stations, escalators shall have a minimum clear width of 32 inches. At the top and bottom of each escalator run, at least two contiguous treads shall be level beyond the comb plate before the risers begin to form. All escalator treads shall be marked by a strip of clearly contrasting color, 2 inches in width, placed parallel to and on the nose of each step. The strip shall be of a material that is at least as slip resistant as the remainder of the tread. The edge of the tread shall be apparent from both ascending and descending directions.

(17) Where provided, elevators shall be glazed or have transparent panels to allow an unobstructed view both in to and out of the car. Elevators shall comply with 4.10.

EXCEPTION: Elevator cars with a clear floor area in which a 60 inch diameter circle can be inscribed may be substituted for the minimum car dimensions of 4.10, Fig. 22.

(18) Where provided, ticketing areas shall permit persons with disabilities to obtain a ticket and check baggage and shall comply with 7.2.

(19) Where provided, baggage check-in and retrieval systems shall be on an accessible route complying with 4.3, and shall have space immediately adjacent complying with 4.2. If unattended security barriers are provided, at least one gate shall comply with 4.13. Gates which must be pushed open by wheelchair or mobility aid users shall have a smooth continuous surface extending from 2 inches above the floor to 27 inches above the floor.

10.3.2 Existing Facilities: Key Stations.

(1) Rapid, light and commuter rail key stations, as defined under criteria established by the Department of Transportation in subpart C of 49 C.F.R. part 37 and existing intercity rail stations shall provide at least one accessible route from an accessible entrance to those areas necessary for use of the transportation system.

(2) The accessible route required by 10.3.2(1) shall include the features specified in 10.3.1(1), (4)-(9), (11)-(15), and (17)-(19).

(3) Where technical infeasibility in existing stations requires the accessible route to lead from the public way to a paid area of the transit system, an accessible fare collection system, complying with 10.3.1(7), shall be provided along such accessible route.

(4) In light rail, rapid rail and commuter rail key stations, the platform or a portion thereof and the vehicle floor shall be coordinated so that the vertical difference, measured when the vehicle is at rest, is within plus or minus 1-1/2 inches under all normal passenger load conditions, and the horizontal gap, measured when the vehicle is at rest, is no greater than 3 inches for at least one door of each vehicle or car required to be accessible by 49 C.F.R. part 37.

EXCEPTION 1: Existing vehicles retrofitted to meet the requirements of 49 C.F.R. 37.93 (one-car-per-train rule) shall be coordinated with the platform such that, for at least one door, the vertical difference between the vehicle floor and the platform, measured when the vehicle is at rest with 50% normal passenger capacity, is within plus or minus 2 inches and the horizontal gap is no greater than 4 inches.

EXCEPTION 2: Where it is not structurally or operationally feasible to meet the horizontal gap or vertical difference requirements, mini-high platforms, car-borne or platform mounted lifts, ramps or bridge plates, or

similar manually deployed devices, meeting the applicable requirements of 36 C.F.R. part 1192, or 49 C.F.R. part 38, shall suffice.

(5) New direct connections to commercial, retail, or residential facilities shall, to the maximum extent feasible, have an accessible route complying with 4.3 from the point of connection to boarding platforms and all transportation system elements used by the public. Any elements provided to facilitate future direct connections shall be on an accessible route connecting boarding platforms and all transportation system elements used by the public.

10.3.3 Existing Facilities: Alterations.

(1) For the purpose of complying with 4.1.6(2) (Alterations to an Area Containing a Primary Function), an area of primary function shall be as defined by applicable provisions of 49 C.F.R. 37.43(c); (Department of Transportation's ADA Rule) or 28 C.F.R. 36.403 (Department of Justice's ADA Rule).

Accessibility Checklist

The Americans with Disabilities Act (ADA) requires that new and altered transit facilities be accessible. Title II of the ADA covers sidewalk and street construction and transit accessibility, referencing the ADA Accessibility Guidelines (ADAAG) or the Uniform Federal Accessibility Standards (UFAS) for new construction and alterations undertaken by or on behalf of a state or local government. The Department of Justice (DOJ) Title II regulation specifically requires that curb ramps be provided when sidewalks or streets are newly constructed or altered.

Bus Stop Sites and Alterations

Surface:

Are bus stop sites chosen such that, to the maximum extent practicable, the areas where lifts or ramps are to be deployed are on stable and firm surfaces?

Clear Dimensions:

Is there a clear length of at least 96-inches (measured from the curb or vehicle roadway) and a clear width of at least 60-inches (parallel to the roadway) provided to the maximum extent allowed by legal or site constraints?

Bus Stop Pad

Surface:

If a bus stop pad has been newly constructed at a bus stop, bay or other area where a lift or ramp is to be deployed, does it have a surface that is stable?

Clear Dimensions:

Is there a clear length of at least 96-inches (measured from the curb or vehicle roadway) and a clear width of at least 60-inches (parallel to the roadway) provided to the maximum extent allowed by legal or site constraints?

Connection to Pedestrian Way:

Is the pad connected to streets, sidewalks or pedestrian paths by an accessible route?

Slope:

Is the slope of the pad parallel to the roadway and, to the extent practicable, the same as that of the roadway?

Note: A maximum slope of 1:50 (2%) perpendicular to the roadway is allowed for water drainage.

Bus Shelter

Position:

Where provided, are new or replaced bus shelters installed or positioned in such a way that a wheelchair or mobility aid user can enter from the public way and reach a location having a minimum clear floor area of 30-inches by 48-inches, entirely within the perimeter of the shelter?

Connection to Boarding Area:

Are such shelters connected by an accessible route to the boarding area provided? (Use Form 3: Exterior Accessible Routes)

Signs

Finish:

Do the characters and background on such signs have a non-glare finish?

Character Proportion:

Do the letters and numbers on such signs have a width-to-height ratio between 3:5 and 1:1; and a stroke width-to-height ratio between 1:5 and 1:10?

Character Size:

Are the characters on such signs sized according to viewing distance with characters on overhead signs at least 3-inches high?

Note: Signs that are sized to the maximum dimensions permitted under legitimate local, state or federal regulations or ordinances shall be considered in compliance.

Exceptions: Bus schedules, timetables, or maps that are posted at the bus stop or bus bay are not required to comply with this provision.

Appendix B - SUGGESTIONS FOR FURTHER CONSIDERATION

While this report outlines the necessary steps for shaping the urban environment to achieve economical and effective transit service, we can do much more to improve the efficiency and effectiveness of transit services. Possible options for future consideration include:³

Pre-designate a future system of transit corridors.

It is important to take a long range view and to map out corridors where there will be a commitment to provide a higher level of transit service, particularly in terms of shorter headways and extended service hours. Votran and local governments should jointly identify these future corridors of transit service before development patterns become established. Transit Corridor Districts (TCD) where transit-supportive land use will be promoted should be designated along these corridors, and particularly at key nodes (e.g., where two or more transit routes cross or at inter-modal transportation terminals).

Design for a phased implementation of transit corridors.

The designation and official zoning of a Transit Corridor District (TCD) is the first step toward implementing transit service. The local government should develop standards by which the corridors' growth will be measured. After growth in population and building has occurred, additional service should be added. The additional service should include the improvement and expansion of transit stop facilities. The local government should develop a schedule, based on the amount of development, showing when upgrades will be made to services and stops.

Modify zoning and land development regulations through the designation of Transit Corridor Districts (TCDs).

Local governments should consider amending their zoning and land development regulations to accommodate the concept of a Transit Corridor District (TCD) as a new zoning district. The TCD would be similar to a Planned Unit Development (PUD) because it incorporates many aspects found in other zoning districts. The TCD should have transit service as a main objective. Mixed use development should be encouraged and projects in the TCD should have to meet all district level guidelines. The idea of a TCD focuses transit service and develops a separation of land uses that relate well to transit from those that relate to the automobile.

- Provide mixed land use including housing, office, retail, light industrial and recreational uses.

This guideline would be implemented by developing special zoning categories at transit stops. Larger projects would be encouraged that contained a ratio of uses (for example, a ratio of office space to residential units, with flexibility). Single parcel, mixed use developments provide better interaction between different land uses than separate, adjacent parcels with different land uses. Another option would be to zone on a small parcel level to ensure a variety of compatible uses adjacent to one another.

- Parking requirements in TCDs should reflect availability of transit services.

Parking requirements can be modified in Transit Corridor Districts. Specific parking requirements in a TCD should be covered by provisions for a parking gradient or the provision of different levels of parking based on proximity to transit. Parking requirements in the current zoning ordinance should be reviewed. Most likely, the ordinance has minimum levels of parking that must be provided and changes should be made to lower the minimum number of spaces required in areas where transit is present. There could be two sets of minimums for land outside of TCDs. Minimum levels of parking for land uses that are not compatible with, or near, transit services should be set to accommodate all patrons as auto travelers.

³ These suggestions are based on IMPLEMENTATION ISSUES FOR TRANSIT SENSITIVE SUBURBAN LAND USE DESIGN, Beimborn, Rabinowitz, and Gugliotta, The Center for Urban Transportation Studies, University of Wisconsin at Milwaukee, Milwaukee, WI, July 1995.

- Control of through automobile traffic.

Successful TCDs could generate large amounts of automobile traffic and will interfere with the ability to provide high quality transit service. It would be very difficult to close an existing roadway after substantial development has occurred. Early location of no-auto zones along the transit route before development is critical and will limit automobile interference. These can be protected through official mapping and/or the zoning map.

Explore public/private opportunities for transit stop joint development.

A most opportune location for joint development by the private and public sectors is at transit stops. Local governments should consider a proactive approach to development surrounding stops. Large stops can become part of the surrounding buildings. Developers may pay to construct sheltered stop areas that tie directly to their buildings and revert the actual right-of-way to the local government. The main benefit for the developer is the increased patronage that will flow from the transit stop directly in to the building. For the local government, capital costs are reduced.

At smaller stops, simple retail services can become part of joint development efforts. The presence of retail services at transit stops can be contracted out to businesses for different services. This also allows small businesses to become established in each neighborhood. Another alternative is to seek joint development opportunities with private companies. In return for providing some of the needed funds to develop the transit stop, a private firm is allowed to use the adjacent land for retail service provision.

[See Votran's Joint Development Policy on page 65.]

Use transit corridors for primary pedestrian, bicycle and transit movement.

The zoning code and development review process should be modified to assure that there is a provision for separate, high quality, pathways for pedestrians and bicycles. All cul-de-sacs should include pathways at their ends to connect to surrounding streets. Logical pathways should be provided to provide direct connections between different parts of developments. Sufficient rights-of-way should be reserved (through official mapping) to permit separate, parallel bike and pedestrian paths along transit corridors and arterials within transit service zones.

Relate the design and connections of adjacent developments across "seams".

The ability to tie together individual development projects is critical to the success of a Transit Corridor District. Developers should be allowed considerable flexibility in their planning within a project; however, project review and stipulations must assure that adjacent developments fit together. Conditions that should be met include maintenance of the continuity of transit roadways, circulation between adjacent properties, provision of easements on rights-of-way for pathways and appropriate adjacencies of land use.

Develop a program to encourage shared parking facilities.

To encourage the use of shared parking lots, the local government should require each proposed project to identify all parking facilities on adjacent parcels and explore the feasibility of their use as shared lots. Local government also could approve development proposals on the condition that the land owner sign an agreement stating that they will arrange for joint use of parking facilities whenever deemed feasible by the local government.

Minimize the distance between building entrances and transit stops, provide logical connections between buildings and transit.

A basic tenet that should be implemented in the zoning/building code is that pathways should be provided between transit stops and building entrances. This is seldom done in suburban areas; often it is necessary for a user to walk across lawns or through parking lots to reach a building. This regulation also would specify a maximum walking distance from transit stops to building entrances.

Building location and design should be sensitive to transit-generated noise and views.

This guideline can be easily adapted to a zoning code. Either the local government can maintain a very large right-of-way along the transit path, or building setback requirements can be regulated to keep residents removed from the sight and noise. Setbacks should be greater near transit stops for residential buildings

where vehicle acceleration and braking noise is loudest. Commercial buildings can be permitted to be closer to the transit line than residential uses. In addition to the increased setback distances, trees and berms can be used to block the view of the transitway. Local government should have a policy of maintaining tree plantings along the transit rights-of-way.

Plan for a high quality pedestrian/bicycle pathway system.

As part of the TCD, a pathway system of public rights-of-way should be developed within its boundaries. This system should be mapped out and be designed with area-wide connectivity. Private developments also should become part of this system. The local government would require each developer to submit a pedestrian/bicycle pathway plan. The plan should show how pedestrians and bicycles will be able to cross the property and how the pathways will connect into the overall pathway system. All cul-de-sacs should have pathways that lead from their ends to adjacent streets. The local government should maintain an updated pathway system map.

Provide financial and other incentives to promote transit-supportive development in Transit Corridor Districts and other selected places.

Local governments can recognize and reward the reduced traffic impacts of transit-supportive development by offering relief from transportation impact fees and/or exceptions from transportation concurrency requirements.

Changes to the use of impact fees as legislatively enacted in 1999 through the creation of the multi-modal transportation district option, has had the effect of further reducing the effectiveness of impact fees to raise revenue for roadway improvements. More recent legislation for multi-modal transportation districts includes the provision that “Local governments may reduce impact fees or local access fees for development within multimodal transportation districts based on the reduction of vehicle trips per household or vehicles miles of travel expected from the development pattern planned for the district.” The intended effect is to encourage developers to adopt development patterns as promoted by multi-modal transportation districts. While this will not raise funds for transit, it should have the positive effect of putting appropriate land development patterns in place that make bus transit more effective and efficient.

There may be a missed opportunity when impact fees are considered only for roadways and no other form of transportation. While there may be a reduction of vehicle trips per household, there will almost certainly still be a need for transportation, in one form or another. Broadening our view toward the development of a “transportation impact fee” might open new opportunities to fund transit using private sector land developer participation.

Higher density and intensity should be “by right” in Transit Corridor Districts; but local governments could allow even higher density and/or intensity as a bonus to any developer who will go beyond the minimum threshold to make his development transit-friendly.

Other incentives that can be explored are use of proportionate fair share mitigation⁴ to fund transit improvements, community redevelopment areas/tax increment financing districts and publicly funded

⁴ Subsection (16) of Section 163.3180, Florida Statutes, requires each local government to enact a concurrency management system to ensure that no development will be approved unless adequate capacity is available in essential support facilities and services. The provision further outlines a “proportionate fair-share mitigation” option for transportation facilities. So, when transportation capacity is not available for development, a developer may opt to “pay to play” if certain conditions exist. These conditions, created by SB 360, have been summarized by the law firm of Hopping Green & Sams, “a developer may choose to satisfy all transportation concurrency requirements by contributing its proportionate share if transportation facilities identified as mitigation for traffic impacts are:

1. Specifically identified for funding in the five-year schedule of capital improvements in the [CIE] of the local plan, or
2. Identified in the long-term concurrency management system, or
3. If contributions or payments for such facilities or segments are reflected in a five-year schedule of a capital improvement plan in the next regularly scheduled update of the local [CIE].”

If one of the three above conditions has been met by the local government, a developer must be afforded the opportunity to mitigate their impacts through monetary or “proportionate fair-share” contributions. Furthermore, additional options for proportionate fair-share are available at a local government’s discretion, even if the conditions identified above are not met.

improvements to area infrastructure (e.g., district-wide parking and stormwater management systems) and streetscapes.

Appendix C - VOTRAN'S JOINT DEVELOPMENT POLICY

Votran encourages partnerships with public agencies and private developers to jointly develop transit facilities and services for the purpose of promoting public transportation. Joint development supports Votran's mission by providing a means to facilitate the delivery of efficient and cost-effective public transit, to increase fare box recovery rates and to contain transit capital and operating costs. Votran promotes the joint use of properties for private and public sector development in a manner that is compatible with transit service delivery and public convenience.

Therefore, Votran encourages public agencies and private developers to propose co-development of real estate when such projects will support public transit and provide financial and/or locational benefits to the development partner, the local jurisdictions, the general public and Votran.

Votran reserves the right to accept or reject all joint development proposals without cause. Votran will not participate in joint development projects where substantial transit benefits cannot be realized. For this reason, proposals for joint development will be evaluated based on the following project characteristics:

- area transit facility and service needs;
- transit ridership projections and revenue generation;
- proposed and existing land use mix and densities;
- community interests;
- local government comprehensive plans;
- start-up and ongoing capital and operating expenditures;
- site characteristics;
- project scope;
- site characteristics;
- project scope;
- land development and zoning regulations;
- traffic and parking impact; and
- environmental impact.

In order to ensure that joint development agreements are negotiated in a timely manner, all such agreements will specify land use and density, private and public sector roles, infrastructure installation, architectural design, construction schedules, building maintenance aspects, and financial considerations including financing options and all necessary legal agreements with local jurisdictions. In order to facilitate joint development, local officials are encouraged to establish comprehensive and consistent land use and zoning regulations that support joint development projects. Similarly, support is expressed for streamlining local regulatory processes governing joint development and for formulating intergovernmental agreements relating to regional development in general.

Votran is interested in pursuing joint development project proposals that meet the following objectives:

- to increase transit ridership and fare box revenues;
- to decrease transit operating expenses;
- to generate revenue through the lease, sale or con-development of Votran properties;
- to conserve grant capital by reducing land acquisition and construction costs through shared expenses;
- to facilitate economic development desired by local jurisdictions;

- to minimize property removed from tax rolls;
- to promote land use patterns and architectural designs that are conducive to transit operations in conformance with Votran plans, regional transportation programs, local development plans and community interests;
- to establish compatible development projects on transit properties for the enhancement of short- and long-range transit market potential; and
- to improve the quality of life in suburban communities by increasing access to public transportation, minimizing traffic congestion, improving environmental quality through the reduction of vehicle emissions, fuel consumption and roadway expansions and by offering convenience facilities for transit users.

Appendix D - RELATED STATUTES AND RULES

Transportation Concurrency Exception Areas (TCEAs)

Availability of public transit service may have great importance relative to a local government's ability to grant transportation exceptions to concurrency. Florida Statutes., 163.3180 describes why and under what circumstances such exceptions may be granted:

163.3180 (5)(a) "The Legislature finds that under limited circumstances dealing with transportation facilities, countervailing planning and public policy goals may come into conflict with the requirements that adequate public facilities and services be available concurrent with the impact of such development. The Legislature further finds that often the unintended result of the concurrency requirement for transportation facilities is the discouragement of urban infill development and redevelopment. Such unintended results directly conflict with the goals and policies of the state comprehensive plan and the intent of this part. Therefore, exceptions from the concurrency requirement for transportation facilities may be granted as provided by this subsection."

Part (5)(b) defines the requirements of development in a TCEA. In summary:

- The development must, in all other aspects, be consistent with the adopted local government comprehensive plan; and
- The development must promote public transportation or be located within an area designated in the comprehensive plan for urban infill development, urban redevelopment, downtown revitalization, or urban infill and redevelopment under F.S. 163.2517.

When a local government implements a TCEA, it must adopt strategies to promote mobility. These strategies must address urban design, mixed land uses, higher density and intensity of land uses, and connectivity.

163.3180 (5)(e) The local government shall adopt into the plan and implement strategies to support and fund mobility within the designated exception area, including alternative modes of transportation. The plan amendment shall also demonstrate how strategies will support the purpose of the exception and how mobility within the designated exception area will be provided. In addition, the strategies must address urban design; appropriate land use mixes, including intensity and density; and network connectivity plans needed to promote urban infill, redevelopment, or downtown revitalization.

Multimodal Transportation Districts (MMTD)

Chapter 163.3180(15)(d), F.S. allows Florida's local governments to use alternative approaches to concurrency management. Typically, minimum level of service standards are established in local comprehensive plans based solely on automobile usage. In an MMTD, concurrency determinations may be based on multimodal performance measures that consider all of the available modes of transportation, including walking, biking, and transit.

Where minimum automobile level of service standards are exceeded by proposed developments, "local governments may issue development permits in reliance upon all planned community design capital improvements that are financially feasible over the development or redevelopment timeframe, without regard to the period of time between development or redevelopment and the scheduled construction of capital improvements" (2). This statement provides considerable flexibility in accomplishing concurrency, while allowing the intensity and type of development necessary to support multimodal objectives.

Planning & Implementation

MMTD designation is accomplished by amending a local government comprehensive plan and accompanying future land use map, as provided in Chapter 163.3184, F.S. A proposed multimodal transportation district must be reviewed and approved by both the Department of Community Affairs (DCA) and the Florida Department of Transportation (FDOT). Local governments must demonstrate that an area qualifies as an MMTD based upon the following existing or planned future design elements defined in Chapter 163.3180(15)(b), F.S.:

- A complementary mix and range of land uses;
- An interconnected network of streets to encourage walking and bicycling, with traffic calming where desirable;
- Appropriate densities and intensities of use within walking distance of transit stops;
- Daily activities within walking distance of residences, allowing independence to persons who do not drive;
- Public uses, streets, and squares that are safe, comfortable, and attractive for the pedestrian, with adjoining buildings open to the street and with parking not interfering with pedestrian, transit, automobile, and truck travel modes.

Communities considering designating an MMTD are encouraged to review the FDOT Multimodal Transportation Districts and Areawide Quality of Service Handbook (Multimodal Handbook) and to contact the Florida Department of Transportation (FDOT) and the Department of Community Affairs (DCA) early in the process for guidance. The Handbook provides guidelines for local governments to achieve the successful designation of an MMTD. The guidelines are also used in assessing the success of a district by FDOT and DCA.

The FDOT Multimodal Handbook characterizes a “good candidate” as having “a mix of mutually supporting land uses, good multimodal access and connectivity, an interconnected transportation network and the provision of alternative modes of transportation to the automobile.

Although certain elements are required for designation, many of the Multimodal Handbook’s guidelines are recommendations and not rigid standards or thresholds. Flexibility is provided during the review process for proposed districts that fail to meet all applicable standards.

After the plan is amended, consistent local ordinances must be adopted to implement the new district.

Local governments could elect to amend existing land development regulations either through an overlay zone, which adds new regulations onto the underlying zoning district(s), or a special district with new design standards and regulations that are tailored to the MMTD.

Appendix E - CRIME PREVENTION THROUGH ENVIRONMENTAL DESIGN (CPTED)

CPTED (pronounced sĕp' – tĕd) is an acronym for Crime Prevention Through Environmental Design. CPTED is based on the belief that the proper design and effective use of the built environment can lead to a reduction in the incidence and fear of crime and in an improvement in the quality of life.

CPTED recognizes that criminals make rational choices about their targets. In general: (1) the greater the risk of being seen, challenged, or caught; the less likely they are to commit a crime. (2) the greater the effort required, the less likely they are to commit a crime. (3) the less the actual or perceived rewards, the less likely they are to commit a crime.

Through use of CPTED principles, the built environment can be designed and managed to ensure: (1) there is more chance of being seen, challenged, or caught; (2) greater effort is required; (3) the actual or perceived rewards are less; and (4) opportunities for criminal activity are minimized.

CPTED consists of four key concepts: Natural Surveillance, Natural Access Control, Territorial Reinforcement and Maintenance, all of which are interrelated

Natural Surveillance – Is the placement of physical features, activities and people in such a way as to maximize visibility. The greater risk a person faces of being seen, challenged, or caught; the less likely he will be to commit a crime.

Natural Access Control - is the physical guidance of people coming and going from a space by the judicious placement of entrances, fences, landscaping, and lighting. This principle helps deter access to a crime target or victim and creates a perception of risk to a perpetrator. The greater the effort required by a person, the less likely he will be to commit a crime.

Territorial Reinforcement – is the use of physical attributes that express ownership such as fencing, pavement treatments, signage, and landscaping. When a person recognizes another's claim to property -- i.e., that the property has not been abandoned -- the less likely he will be to claim it as his own.

Maintenance – Allows for the continued use of a space for its intended purpose. It also serves as an additional expression of ownership and an indication that the property has not been abandoned.

CPTED DESIGN STRATEGIES

CPTED design strategies are typically used during project development review to identify and incorporate design features which manifest these four key concepts. Commonly used design strategies relating to each of the four concepts are as follows:

Design Strategies for Natural Surveillance:

When you consider design strategies for Natural Surveillance, keep in mind that it occurs when individuals are able see from inside a home, office, business, or other designated area and people outside are able to see inside the home, office, business, or other designated area.

Consider how and where a bus stop, pedestrian pathway, bike storage facility or other potential target for criminal activity is situated, and consider the design and orientation of windows, lighting, entrances, parking lots, etc., to provide maximum surveillance opportunities. Eliminate blind spots and hideouts.

Encourage the presence of more people engaged in lawful activity in a designated area over a longer period of the day, and you will then increase Natural Surveillance opportunities.

Design Strategies for Natural Access Control:

Use fencing material or landscaping to prevent or discourage access into unmonitored areas.

Limit the number of access points into a building.

Install mechanical or electronic locks.

Design Strategies for Territorial Reinforcement:

Use fencing material or landscaping to show ownership (Territorial Reinforcement). Remember to carefully choose materials for fences and landscaping so that you can also provide opportunities for Natural Surveillance and Access Control.

Use signs that clearly display your address or business name on mail boxes and buildings, in parking areas, or along sidewalks.

Use sidewalks and parking areas to provide clues to ownership (Territorial Reinforcement).

Design Strategies for Maintenance:

Use low maintenance or maintenance-free building products in your construction.

Use low maintenance or maintenance-free plants and shrubbery in your landscape design. Consider low maintenance ground covers instead of high-maintenance expanses of grass or lawns.

Use landscaping that has a natural growth habit to meet these standards when located along building entrances, walkways, or in parking lots.

Shrubs – Choose shrubs that can be maintained at a low height so that they will not create blind spots and hideouts.

Trees – Choose trees that grow a canopy that is raised up from the ground, again, to avoid blind spots and hideouts.

Trim shrubs and trees regularly. Keep grass cut and eliminate weeds.

Consider using long life light bulbs for home applications to minimize frequently burned out exterior lighting.

Install dusk to dawn sensors on lighting fixtures. Remember: lighting is the least expensive crime prevention method.

Remove inoperable vehicles, trash, and debris regularly.

CRIME PREVENTION THROUGH ENVIRONMENTAL DESIGN (CPTED) PRACTITIONER DESIGNATION

[Excerpt from <http://myfloridalegal.com/> - the website of the Attorney General of the State of Florida, Charlie Crist.]

HISTORY

The Florida Crime Prevention Training Institute (FCPTI) was established in 1982 in the Office of the Attorney General to provide crime prevention training to Florida's law enforcement community and other interested citizens. In 2004, the **Florida Crime Prevention Through Environmental Design Practitioner Designation** was made available to individuals who successfully completed sixty-four hours of comprehensive CPTED courses offered through FCPTI and/or other recognized training entities.

Designed for crime prevention and community oriented policing officers, planners, and architects, the designation provides officers and civilians with the skills necessary to deliver comprehensive CPTED programs to Florida's residential and commercial industry, as well as local government.

INITIAL DESIGNATION

To earn the CPTED Practitioner designation, a participant must successfully complete sixty-four hours of instruction offered through FCPTI and/or other recognized training entities within a period of two consecutive years. The curriculum includes sixty-four hours of instruction, of which twenty-four hours must include Advanced CPTED training provided by FCPTI:

Basic Crime Prevention Through Environmental Design is a forty hour course which teaches a student the proper design and effective use of the physical environment to achieve a more productive use of space and a reduction of crime; and

Advanced CPTED is a twenty-four hour course which provides instruction in plan review, report writing, presentation skills, lighting, zoning, and behavioral management; and

Other Recognized CPTED Training from a recognized training entity which provides instruction in basic CPTED principles to include the proper design and effective use of the physical environment to achieve a more productive use of space and a reduction of crime.

Students must pass a written examination at the end of each course. Upon successful completion of sixty-four hours of CPTED training, the designation of Florida Crime Prevention Through Environmental Design Practitioner is awarded to the student by Attorney General Charlie Crist.

MAINTAINING THE DESIGNATION

The initial Florida CPTED Practitioner designation is valid for a period of three years from the date that appears on the Florida CPTED Practitioner designation certificate. To maintain the designation, a CPTED Practitioner must successfully complete the eight hour CPTED Practitioner Update course offered by FCPTI, which provides the Practitioner with current information on CPTED issues and trends. Upon successful completion of a CPTED Practitioner Update course, the designation will be renewed for a period of three years from the date of the Update course.

FOR MORE INFORMATION

Additional information on the Florida CPTED Practitioner designation may be obtained by writing the Florida Crime Prevention Training Institute, Office of the Attorney General, PL-01, The Capitol, Tallahassee, Florida 32399-1050, or by calling FCPTI at (850) 414-3360.

These guidelines were developed by VOTRAN and the Volusia County MPO in cooperation with the member local governments.

Funding for this document was provided, in part, by the Federal Highway Administration, the Federal Transit Administration, and the Florida Department of Transportation.

Votran

950 Big Tree Road

South Daytona, Florida 32119-8815

Volusia County MPO

2570 W. International Speedway Blvd.

Suite 120

Daytona Beach, Florida 32114-8145